

# LIMITED WARRANTY

COMPANY NAME: \_\_\_\_\_

COMPANY ADDRESS: \_\_\_\_\_

CITY: \_\_\_\_\_ STATE: \_\_\_\_\_ ZIP: \_\_\_\_\_

MODEL: \_\_\_\_\_

SERIAL NUMBER: \_\_\_\_\_

DATE PURCHASED: \_\_\_\_\_

DEALER NAME: \_\_\_\_\_

DATE WARRANTY CARD RETURNED: \_\_\_\_\_

VIA: \_\_\_\_\_ WEBSITE \_\_\_\_\_ MAIL

***FORCE UNLIMITED LLC***



# FORCE UNLIMITED LLC LIMITED WARRANTY

FORCE Unlimited LLC has manufactured or is distributing the Product or Parts to which this warranty is attached. It warrants that the Product or Parts will, under normal conditions of use and service, be free from material defects due to faulty manufacturing for a period of twelve (12) months from the date of delivery to the original user. If any Product or Part does not conform to this warranty, your Dealer will, at its option, repair or replace parts provided, and you will pay all labor costs and costs for materials other than warranty parts. If Product or Part is defective in materials or workmanship, you must promptly notify your Dealer and return to FORCE Unlimited or fax to 319-283-3086 the warranty registration card within 30 days from the date of delivery to original user. The installation of any Part that did not originate from FORCE Unlimited will void this limited warranty in its entirety. In the event of repair or replacement, the warranty period shall not be extended beyond the original warranty period.

**If you fail to return the warranty registration card (in parts manual) to FORCE Unlimited within thirty (30) days after the date of delivery, this warranty shall not apply and your remedy for any defects in the Product will be your responsibility.**

**The above warranty does not cover:**

- a. Product that is damaged by abuse, neglect, accident, or modification
- b. Fluids, towing, telephone, travel, loss of vehicle, inconvenience
- c. The product itself if parts are installed on the equipment that did not originate from FORCE Unlimited

**The above warranty does not apply under the following conditions:**

- a. When Product has been improperly used or installed, modified, or fails because of defects or inefficiency of components not furnished with the Product
- b. When Product is used for purposes for which it was not originally designed or intended, or is used under abnormal operating conditions
- c. When the Dealer or end-user fails to follow FORCE Unlimited instructions regarding the Product

**This warranty is extended only to the original user and is not transferable. In the event of a warranty claim, you should promptly notify your Dealer and provide the following:**

- a. Model & serial number of the Product
- b. Date of delivery to the original user
- c. Part number of the defective Part
- d. Description of the claim encountered

**FORCE Unlimited LLC will bear no other expense including labor and material costs, other than those specified above. Unless modified in writing and signed by both parties, this Limited Warranty is understood to be the complete and exclusive agreement between the parties. No third party has authority to change or modify this warranty in any aspect.**

## LIMITED WARRANTY

### 2 YRS

SHELL STRUCTURE, SPINNER FRAME (including inferior welds & cracking)  
CONVEYOR GEARBOX (including gears, bearings & seals)

### 1 YR

SPINNER MOTORS & ADAPTERS (including bearings & seals)  
CONVEYOR MOTORS (including bearings & seals)  
VALVE MOTORS & CARTRIDGES  
CONVEYOR CHAIN – BELT & FASTENERS  
CONVEYOR SPROCKETS & BEARINGS  
FAN & CONVEYOR RATE SENSORS

### WEAR ITEMS

SPINNER FINS  
SPINNER DISCS

**MANUFACTURER HAS THE RIGHT TO REPLACE DEFECTIVE OR DAMAGED PARTS  
WITH NEW OR REBUILT AT ITS OWN DISCRETION**

**PARTS DAMAGED FROM ABUSE OR IMPROPER MAINTENANCE NOT COVERED**

**FORCE UNLTD.** SPREADERS\*GPS EQUIPMENT\*CONVEYORS

<b><u>ITEM</u></b>	<b><u>PAGE NO.</u></b>
Conveyor Drive	1
Conveyor Idler	2
Optional Spinner Assembly w/Deflectors	3
Jack Shaft Assembly	5
Optional Spinner Guards & Material Flow Divider	6
Dump Valve for Units w/o PTO	7
Spinner/Conveyor Drive Hydraulics	8
Spinner/Dual Conveyor Drive Hydraulics	8.1
Asphalt Conveyor Drive Hydraulics	8.2
Optional Cab Shield (102" wide boxes)	9
Main Valve Block Assembly (Spinner & Conveyor Setup)	10
Main Valve Block Assembly (Spinner & Conveyor Setup) Visual Reference	10.V
Main Valve Block Assembly (Conveyor Only)	10.1
Hydraulic Reservoir	11
Reservoir/Pump Hydraulics	12
Full Float Fenders & Mudflaps	13
Semi Float Fenders & Brackets	13.1
Truck Tire Fenders & Brackets	13.2
Inverted "V" & Cross Brace Assembly	14
Sensor Wiring Harness	15
Decals	16
Gear Box	17
Belt Over Pintle Chain	18
Feedgate Assembly (Solid Rear Panel)	19
Swinging Endgate & Feedgate Assembly	19.1
Swinging Endgate Catch/Release Assembly	19.2
Optional Hillside Flow Divider	20
Hydraulic Pipes	21
Chain Shields	22
Light Options	23
Front Belt Sealer	24
Box Window - Optional	25
#2 Straight Chain	26
Optional Asphalt Slide	27
Optional Asphalt Chute	28
Remote Conveyor Hydraulics - Optional	29
Chassis Mounted Pro-Force Unit Hydraulic Swinging Endgate - Optional	30
Hydraulic Feedgate - Optional	32
Optional Electric Conveyor Control, No Main Block - with Dump - No Spinner	33
Oil Cooler - Optional	34
Safety Decals	35
Optional 12" High SS Box Extensions	36



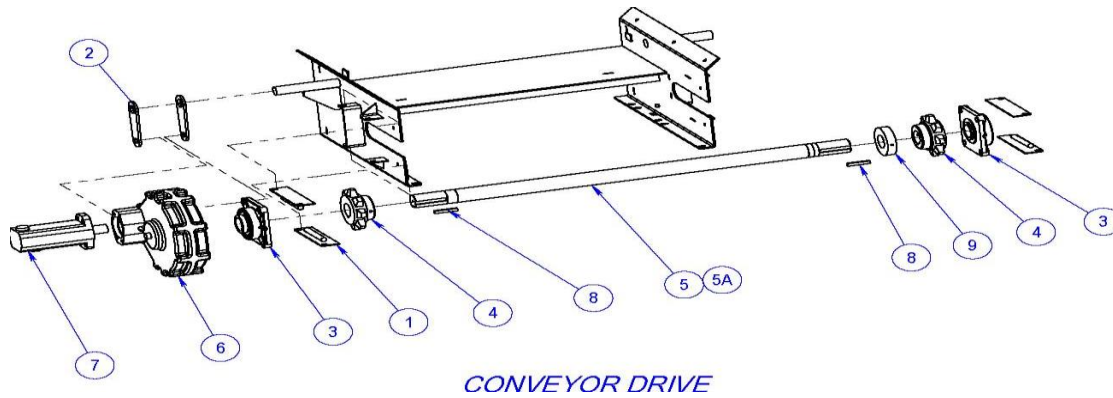

ITEM	PART NO	DESCRIPTION	SINGLE DRIVE QTY	DOUBLE DRIVE QTY
1	1234-102 1200-302SS	Weldment-SS Bearing Slide Requires: (2) Carriage Bolts 3/8" UNC x 1" SS (2) Lock Washer 3/8" SS (2) Nut 3/8" UNC SS Per Slide	4	4
2	1234-11200- 1200-605SS 1205-56	Arm Idler Requires: (1) Hexhead Capscrew - 3/4" UNC x 3-1/2"SS (1) Lock Nut-3/8" SS	2	4
3	1217-102	Bearing Requires: (2) Set Screw - 3/8"-24 UNF x 3/8"Lg. Per Bearing	2	2
4	1217-20	Sprocket-Drive Requires: (2) Set Screw - 3/8" - 16UNC x 1/8"Lg. Per Sprocket	2	2
5	1220-54	Shaft with SS Sleeves Double Drive	0	1
5A	1220-540	Shaft with SS Sleeves	1	0
6	1220-50	Gear Box Requires: (2) Key Square, 1/2" x 2-1/4" Lg. Per Gear Box	1	2
7	1213-145 1213-18 1213-19 1220-145 1200-403 1209-62 1213-145 SK	Motor Hydraulic w/Sensor Motor Hydraulic w/Sensor (Driver's Side) Motor Hydraulic w/o Sensor (Passenger's Side) Requires: (1) Square, 5/16" x 1-1/4" Lg. Per Motor (4) Socket Head Capscrew - 1/2" 1-1/2" Lg. (4) Lock Washer-1/2" Seal Kit	1 0 0	0 1 1
8	1220-525	Key Square, 3/8" x 2-1/2" Lg.	2	2
9	1217-21	Support Roller (1 Required Per Asphalt Only) Requires: (1) Set Screw - 3/8" - 16UNC x 3/8" Lg. Per Roller	1	1

## CONVEYOR IDLER

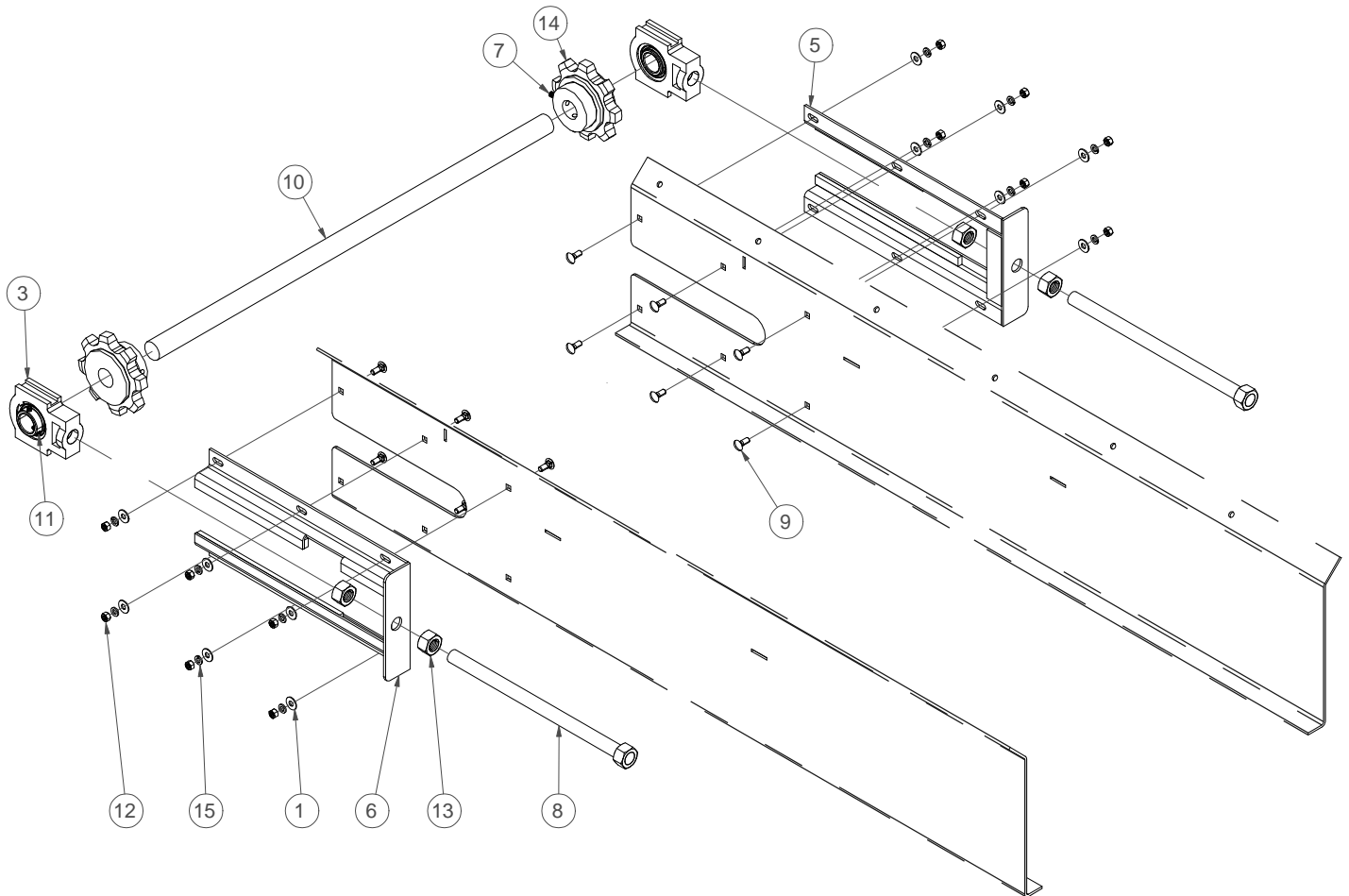

ITEM	PART NO.	DESCRIPTION	QTY
1	1209-40	Flat Washer - 3/8"	12
3	1217-103	Bearing - Take Up	2
5	1234-103 RH	RH Weldment - Take Up	1
6	1234-103	Weldment - Take Up	1
7		Set Screw - 3/8"-24 UNF x 3/8" Lg.	4
8	1225-02	Weldment - Take Up Bolt	2
9	1200-302SS	Carriage Bolt - 3/8" UNC x 1" SS	12
10	1220-515	Shaft - Idler	1
11		Set Screw - 5/16"-24 UNF x 5/16" Lg.	4
12	1205-27	Nut - 3/8" UNC SS	12
13	1205-79	Nut - 1" UNC	4
14	1217-15	Sprocket - Idler	2
15	1209-43	Lock Washer - 3/8" SS	12

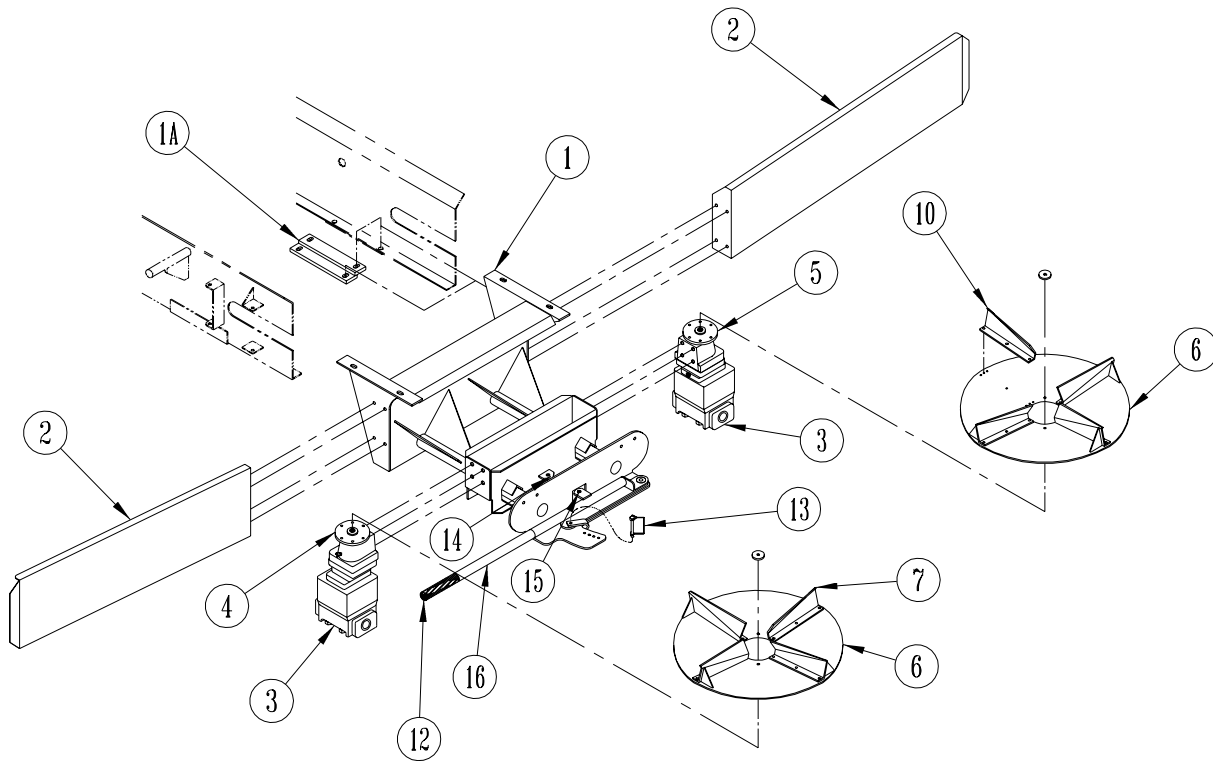

**OPTIONAL SPINNER ASSY. WITH DEFLECTORS**

ITEM	PART NO.	DESCRIPTION	24" ASSY QTY.	30" ASSY QTY.
1	1234-301	Weldment - 24" Spinner Assembly Requires: (4) Carriage Bolt - 1/2" UNC x 2" SS	1	-
	1200-404	(4) Flat Washer - 1/2" SS		
	1209-61	(4) Lock Washer - 1/2" SS		
	1209-63	(4) Lock Washer - 1/2" SS		
	1205-36	(8) Nut - 1/2" UNC SS		
1 A	1218-15	Adapter - Mounting Requires: Same as 1234-301 (Above)	2	-
1	1236-301	Weldment - 30" Spinner Assembly Requires: Same as 1234-301 (Above)	-	1
2	1234-108	Weldment - SS Deflector (132" OA Fender Width)	1 RH, 1 LH	1 RH, 1 LH
2	1234-108MS	Weldment - MS Deflector (132" OA Fender Width) Requires: (4) Hex Head Capscrew - 3/8" UNC x 1" SS		
	1200-3011	(8) Flat Washer - 3/8" SS		
	1209-41	(4) Lock Washer - 3/8" SS		
	1209-43	(4) Lock Washer - 3/8" SS		
	1205-27	(4) Nut - 3/8" UNC SS		
		Per Deflector		
2	1236-108	Weldment - SS Deflector (96" OA Fender Width)		
2	1236-108MS	Weldment - MS Deflector (96" OA Fender Width) Requires: Same as 1234-108 (Above)		
3	1213-15	Motor - Hydraulic (24" Disc) Requires: (Per Motor) (4) Socket Head Capscrew - 1/2" UNC x 1-1/2"	2	-
	1200-403	(4) Lock Washer - 1/2"		
	1209-62	(1) Key - Square, 5/16" x 1-1/2" Lg.		
	1213-155	Replacement Parts: Seal Kit		
	1213-156	Shaft & Gear Set		
3	1213-206	Motor - Hydraulic (30" Disc) Requires: (Per Motor) (4) Socket Head Capscrew - 1/2" UNC x 1-1/2"	-	2
	1200-403	(4) Lock Washer - 1/2"		
	1209-62	(1) Key - Square, 5/16" x 1-1/2" Lg.		
	1213-155	Replacement Parts: Seal Kit		
	1213-145 SK			
4	1218-73	Assembly - Jack Shaft with Sensor Mount (24" Disc) Requires: (1) Hex Head Capscrew - 1/2" UNC x 1" SS	1	-
	1200-400SS	(1) Washer - 1/2" SS		
	1209-61	(4) Hex Head Capscrew - 1/2" UNC x 1-1/4" SS		
	1200-4011	(4) Lock Washer - 1/2" SS		
	1209-63			
4	1218-732M	Assembly - Jack Shaft with Sensor Mount (30" Disc) Requires: Same as 1218-73 (Above)	-	1

**FORCE UNLTD.** SPREADERS\*GPS EQUIPMENT\*CONVEYORS

<b>ITEM</b>	<b>PART NO.</b>	<b>DESCRIPTION</b>	<b>24" ASSY QTY</b>	<b>30" ASSY QTY</b>
5	1218-72	Assembly - Jack Shaft without Sensor Mount (24" Disc) Requires: (1) Hex Head Capscrew - 1/2" UNC x 1" SS	1	-
	1200-400SS	(1) Washer - 1/2" SS		
	1209-61	(4) Hex Head Capscrew - 1/2" UNC x 1-1/4" SS		
	1200-4011	(4) Lock Washer - 1/2" SS		
	1209-63			
5	1218-722M	Assembly - Jack Shaft without Sensor Mount (30" Disc) Requires: Same as 1218-72 (Above)	-	1
6	1218-750	Universal 24" Disc - Dished Requires: (6) Hex Head Capscrew - 1/4" UNC x 1" MS	2	-
	1200-203	(6) Top Lock Nut - 1/4"		
	1205-10	Per Disc		
6	1218-350	Universal 30" Disc - Dished Requires: (6) Hex Head Capscrew - 5/16" UNC x 1-1/4" MS	-	2
	1200-252	(6) Top Lock Nut - 5/16"		
	1205-17	Per Disc		
7	1218-71	Weldment - Fin, Left Hand Requires: Hex Head Capscrew - 5/16" UNC x 3/4" MS	4	6
	1200-250	Hex Head Capscrew - 5/16" UNC x 1" MS	3 Per Fin	3 Per Fin
	1200-251	Top Lock Nut - 5/16"	3 Per Fin	3 Per Fin
	1205-17			
10	1218-70	Weldment - Fin, Right Hand Requires: Hex Head Capscrew - 5/16" UNC x 3/4" MS	4	6
	1200-250	Hex Head Capscrew - 5/16" UNC x 1" MS	3 Per Fin	3 Per Fin
	1200-251	Top Lock Nut - 5/16"	3 Per Fin	3 Per Fin
	1205-17			
12	1218-01	Grip - Foam	1	1
13	1218-04	Adjusting - Safety Snap Pin	1	1
14	1225-01	Threaded Rod - Fine, 1/2" x 3" Lg., SS Requires: (2) Nut - Hex 1/2" UNF MS	1	1
	1205-38			
15	1218-02	Rod End - Ball Joint, SS Requires: (1) Flat Washer - 1/2" SS	2	2
	1209-61	(1) Lock Nut - Nylon Insert, Thin 1/2" UNC SS		
	1205-39	(1) Hex Head Capscrew - 1/2" UNC x 1-1/2" SS		
	1200-350	Per Rod End		
16	1218-03	Weldment - Adjusting Handle Requires: (1) Washer - Oversized	1	1
	1218-06	(1) Hex Head Capscrew - 1/2" UNC x 1-1/2" SS		
	1200-350	(1) Lock Nut - Nylon Insert, Thin 1/2" UNC SS		
	1205-39			

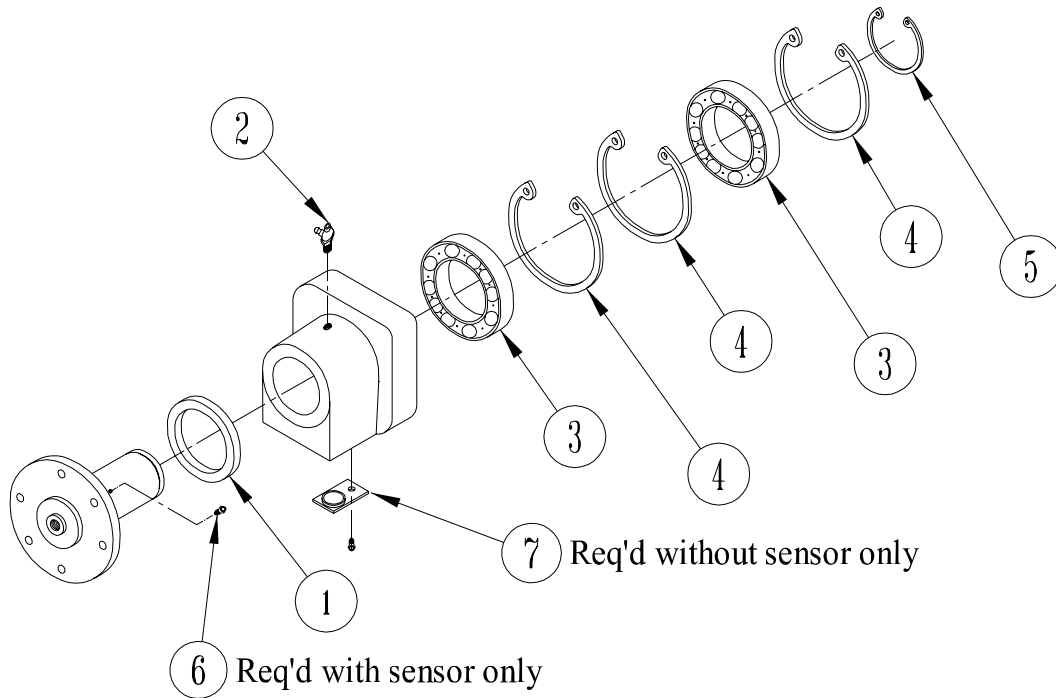

**JACK SHAFT ASSEMBLY**

ITEM	PART NO.	DESCRIPTION	24" ASSY QTY.	30" ASSY QTY.
1	1204-06	Seal - Oil	1	1
2	1204-02	Fitting - Grease	1	1
3	1217-104	Bearing - Ball	2	2
4	1208-05	Snap Ring - Internal	3	3
5	1208-06	Snap Ring - External	1	1
6	1200-245	Cap Screw - Socket Head 10-24 x 1/4"	4	4
7	1218-735	Kit - Sensor Hole Plug Includes: (1) Plug Plate (1) O-ring (1) Screw - 1/4-20 x 1/2" SS Philips Pan Head	As Req'd	As Req'd
	1218-72	Assembly - Jack Shaft without Sensor Mount	1	-
	1218-73	Assembly - Jack Shaft with Sensor Mount	1	-
	1218-722	Assembly - Jack Shaft without Sensor Mount	-	1
	1218-732	Assembly - Jack Shaft with Sensor Mount	-	1

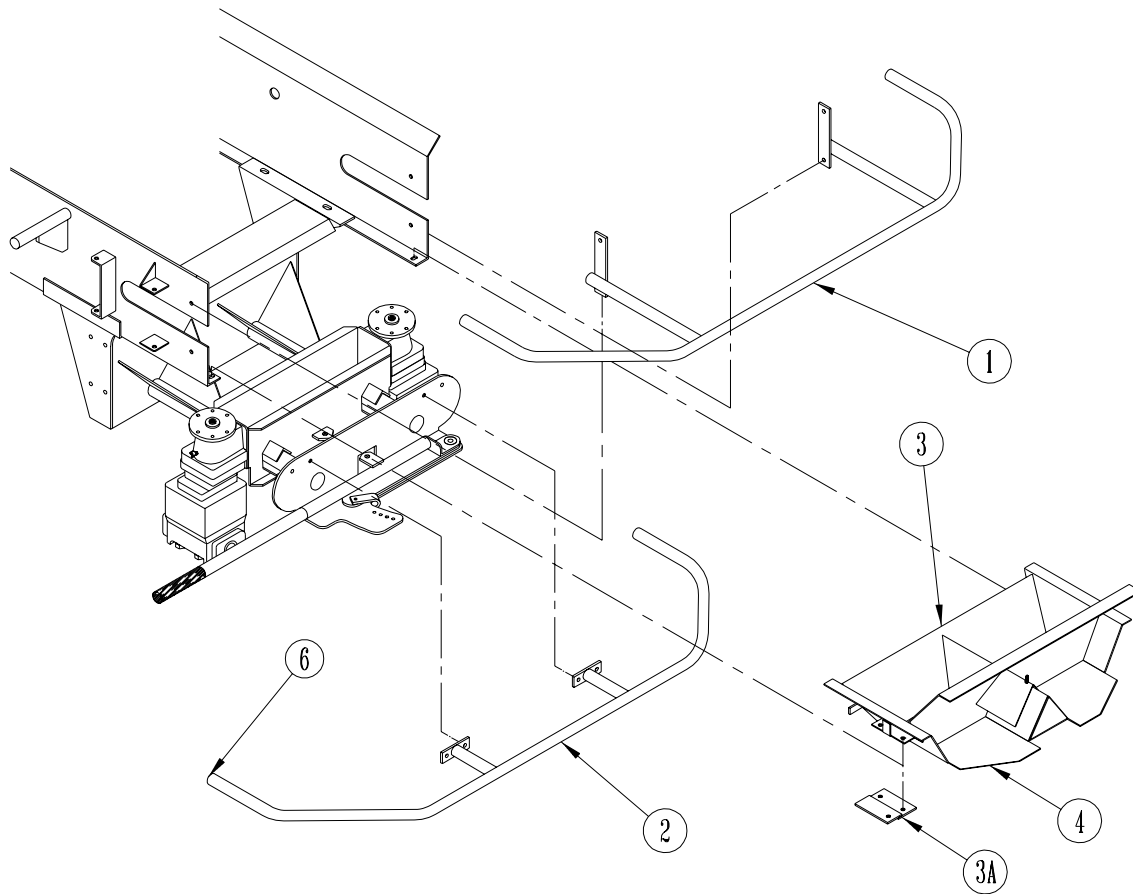

**OPTIONAL SPINNER GUARDS AND MATERIAL FLOW DIVIDER**

<u>ITEM</u>	<u>PART NO.</u>	<u>DESCRIPTION</u>	<u>24" ASSY QTY.</u>	<u>30" ASSY QTY.</u>
1	1236-305	Weldment - 24" Spinner Guard, Upper Requires: 1200-303SS (4) Hex Head Capscrew - 3/8" UNC X 1-1/4" SS 1209-41 (8) Flat Washer - 3/8" SS 1205-26 (4) Lock Nut - 3/8" UNC SS	1	-
1	1236-307	Weldment - 30" Spinner Guard, Upper Requires: Same as 1236-305 (Above)	-	1
2	1234-306	Weldment - 24" Spinner Guard, Lower Requires: 1200-303SS (4) Hex Head Capscrew - 3/8" UNC X 1-1/4" SS 1209-41 (8) Flat Washer - 3/8" SS 1205-26 (4) Lock Nut - 3/8" UNC SS	1	-
2	1236-308	Weldment - 30" Spinner Guard, Lower Requires: Same as 1234-306 (Above)	-	1
3	1236-402A	Weldment - 24" Material Flow Divider, Front Plate Requires: 1200-3011 (2) Hex Head Capscrew - 3/8" UNC X 1" SS 1209-41 (2) Flat Washer - 3/8" SS 1209-43 (2) Lock Washer - 3/8" SS 1205-27 (2) Nut - 3/8" UNC SS	1	-
3A	1236-404	Adapter - Mounting Requires: Same as 1234-402 (Above) Per Adapter	1-RH, 1-LH	-
3	1236-402	Weldment - 30" Material Flow Divider, Front Plate Requires: Same as 1234-402 (Above)	-	1
4	1234-403	Weldment - 24" Material Flow Divider, Back Plate Requires: 1209-41 (1) Flat Washer - 3/8" SS 1205-26 (1) Lock Nut - 3/8" SS	1	-
4	1236-403	Weldment - 30" Material Flow Divider, Back Plate Requires: Same as 1234-403 (Above)	-	1
6	1218-05	Plug - Tube, Poly	6	6



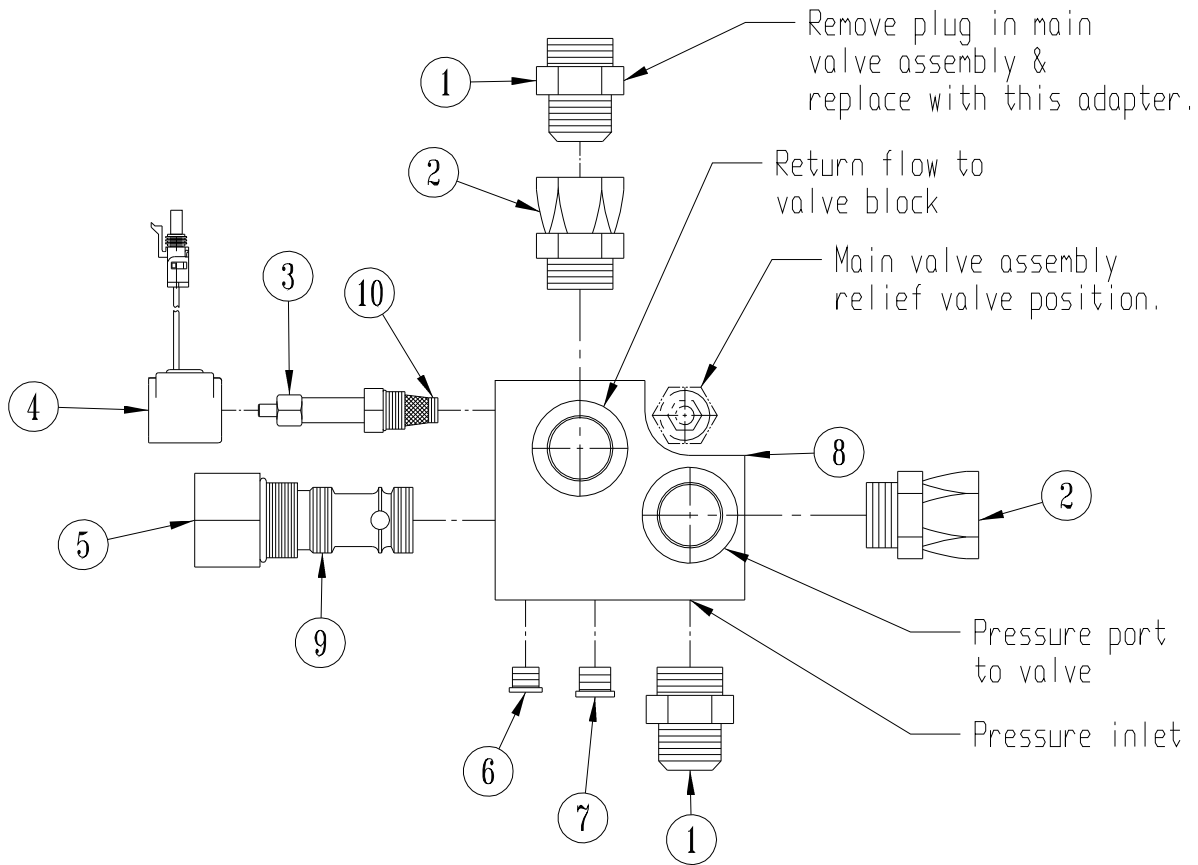

## DUMP VALVE FOR UNITS W/O PTO

ITEM	PART NO.	DESCRIPTION	QTY
1	1202-116	Adapter - Straight	2
2	1202-117	Adapter - Straight	2
3	1222-1090	Valve - Solenoid Normally Open (w/manual override) **If replacing on unit prior to 2007 toggle switch wires may have to be switched .	1
4	1222-109CA	Coil	1
5	1222-108	Valve - Cartridge	1
6	1202-118	Plug	1
7	1202-1193	Plug	1
8	1211-175	Block - Hyd. System Dump Valve	1
9	1222-108K	Seal Kit	1
10	1222-109K	Seal Kit	1
	1223-176	Cable - Dump Valve Switch (Not Shown)	1
	1211-176	Assy - Dump Valve (Includes Items: 1, 2, 3, 4, 5 & 8)	1

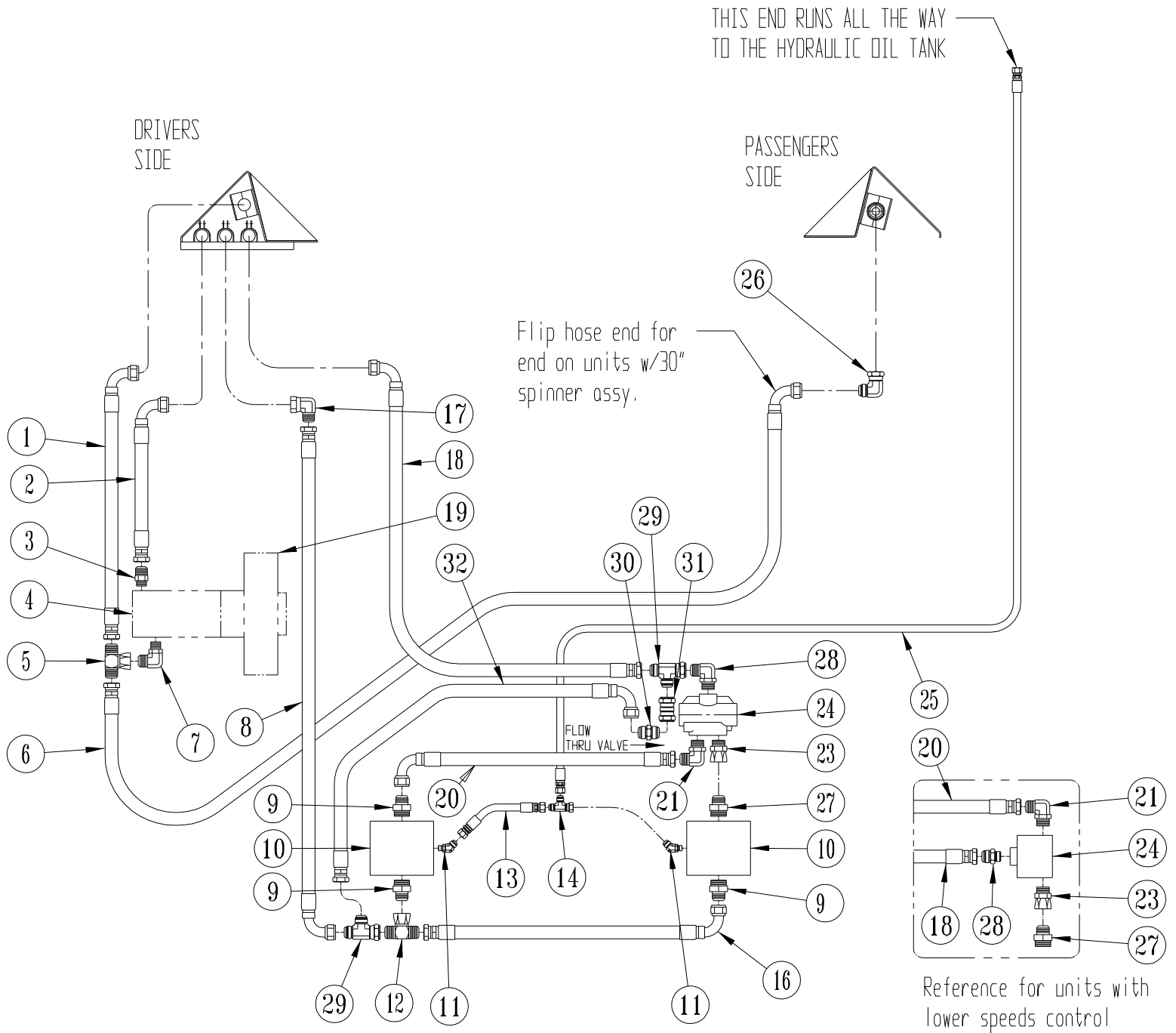

## SPINNER/CONVEYOR DRIVE HYDRAULICS

**FORCE UNLTD.** SPREADERS \* GPS EQUIPMENT \* CONVEYORS

<b>ITEM</b>	<b>PART NO.</b>	<b>DESCRIPTION</b>	<b>QTY</b>
1	1207-03	Hose Ass'y	1
2	1207-04 (Agforce) 1207-041 (Pro-Force)	Hose Ass'y	1
3	1202-111	Adapter - Straight	1
4		Motor - Hydraulic (See Pg. 1)	
5	1202-300 (24" Spinner Assy) 1202-3015 (30" Spinner Assy)	Adapter - Tee	1
6	1207-06 (24" Spinner Assy) 1207-065 (30" Spinner Assy)	Hose Ass'y	1
7	1202-204	Adapter - Elbow	1
8	1207-07 (24" Spinner Assy) 1207-075 (30" Spinner Assy)	Hose Ass'y	1
9	1202-112 (24" Spinner Assy) 1202-111 (30" Spinner Assy)	Adapter - Straight	3
10		Motor - Hydraulic, Spinner (See Pg. 3)	
11	1202-208	Adapter - 45 Deg.	2
12	1202-300	Adapter - Tee	1
13	1207-11 (24" Spinner Assy) 1207-111 (30" Spinner Assy)	Hose	1
14	1202-3014	Adapter - Tee	1
15			
16	1207-02 (24" Spinner Assy) 1207-021 (30" Spinner Assy)	Hose Ass'y	1
17	1202-200	Adapter - Elbow	1
18	1207-05 (24" Spinner Assy) 1207-055 (30" Spinner Assy)	Hose Ass'y	1
19		Gear Box (See Pg. 1)	
20	1207-01 (24" Spinner Assy) 1207-03 (24" Spinner Assy w/Lower Spinner Speeds Control) 1207-011 (30" Spinner Assy)	Hose Ass'y	1
21	1202-201 (STD Spinner Speeds Control) 1202-204 (Lower Spinner Speeds Control)	Adapter - Elbow	1
22			
23	1202-117 (STD Spinner Speeds Control) 1202-1171 (Lower Spinner Speeds Control)	Adapter - Straight	1
24	1211-18 (STD Spinner Speeds Control) 1211-181 (Lower Spinner Speeds Control) 1211-18SP (30" Spinner Assy)	Valve - Flow Divider	1
25	(12' BOX) 1207-08 (13' BOX) 1207-09 (14' BOX) 1207-10	Hose Ass'y	1
26	1202-200 (30" Spinner Assy)	Adapter - Elbow	1
27	1202-112 (24" Spinner Assy w/STD Speeds Control) 1202-1105 (24" Spinner Assy w/Lower Spinner Speeds Control) 1202-111 (30" Spinner Assy w/STD Speeds Control) 1202-110 (30" Spinner Assy w/Lower Spinner Speeds Control)	Adapter - Straight	1
28	1202-201 (STD Spinner Speeds Control) 1202-111 (Lower Spinner Speeds Control)	Adapter - Elbow Adapter - Straight	1
29	1202-3015 (30" Spinner Assy)	Adapter - Tee	2
30	1211-603 (30" Spinner Assy)	Check Valve	1
31	1202-6516 (30" Spinner Assy)	Adapter - Straight	1
32	1207-132 (30" Spinner Assy)	Hose Ass'y	1

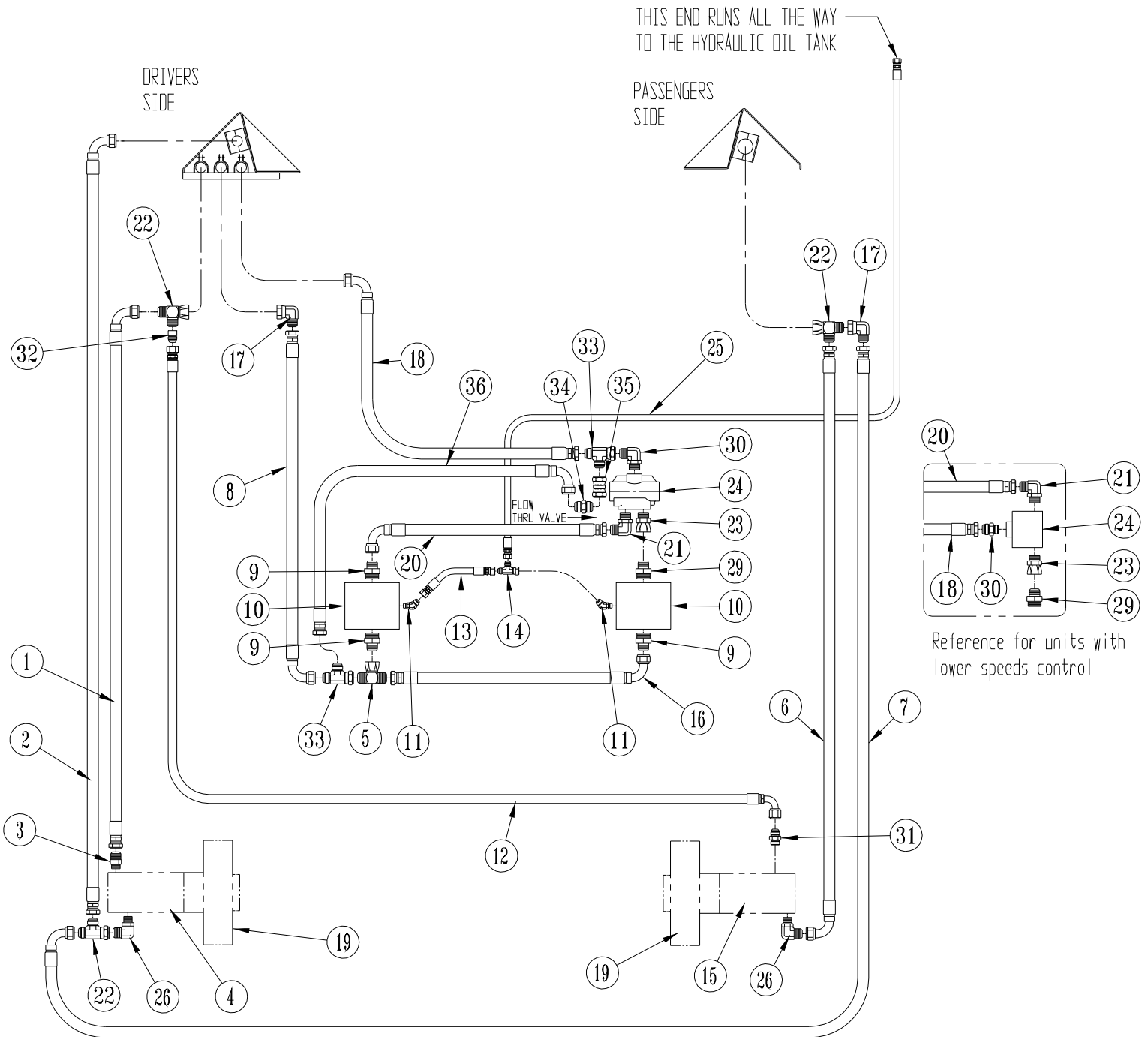

**SPINNER/ DUAL CONVEYOR DRIVE HYDRAULICS**

**FORCE UNLTD.** SPREADERS \* GPS EQUIPMENT \* CONVEYORS

<b>ITEM</b>	<b>PART NO.</b>	<b>DESCRIPTION</b>	<b>QTY</b>
1	1207-04 (Agforce) 1207-041 (Pro-Force)	Hose Ass'y	1
2	1207-03	Hose Ass'y	1
3	1202-111	Adapter - Straight	1
4		Motor - Hydraulic (See Pg. 1)	
5	1202-300	Adapter - Tee	1
6	1207-062	Hose Ass'y	1
7	1207-06 (24" Spinner Assy) 1207-065 (30" Spinner Assy)	Hose Ass'y	1
8	1207-07(24" Spinner Assy) 1207-075 (30" Spinner Assy)	Hose Ass'y	1
9	1202-112 (24" Spinner Assy) 1202-111 (30" Spinner Assy)	Adapter - Straight	3
10		Motor - Hydraulic, Spinner (See Pg. 3)	
11	1202-208	Adapter - 45 Deg.	2
12	1207-042 (24" Spinner Assy) 1207-0425 (30" Spinner Assy)	Hose Ass'y	1
13	1207-11 (24" Spinner Assy) 1207-111 (30" Spinner Assy)	Hose	1
14	1202-3014	Adapter - Tee	1
15		Motor - Hydraulic (See Pg. 1)	
16	1207-02 (24" Spinner Assy) 1207-021 (30" Spinner Assy)	Hose Ass'y	1
17	1202-200	Adapter - Elbow	2
18	1207-05 (24" Spinner Assy) 1207-055 (30" Spinner Assy)	Hose Ass'y	1
19		Gear Box (See Pg. 1)	
20	1207-01 (24" Spinner Assy) 1207-03 (24" Spinner Assy w/Lower Spinner Speeds Control) 1207-011 (30" Spinner Assy)	Hose Ass'y	1
21	1202-201 (STD Spinner Speeds Control) 1202-204 (Lower Spinner Speeds Control)	Adapter - Elbow	1
22	1202-3015	Adapter - Tee	3
23	1202-117 (STD Spinner Speeds Control) 1202-1171 (Lower Spinner Speeds Control)	Adapter - Straight	1
24	1211-18 (STD Spinner Speeds Control) 1211-181 (Lower Spinner Speeds Control) 1211-18SP (30" Spinner Assy)	Valve - Flow Divider	1
25	(12' BOX) 1207-08 (13' BOX) 1207-09 (14' BOX) 1207-10	Hose	1
26	1202-204	Adapter - Elbow	2
27			
28			
29	1202-112 (24" Spinner Assy w/STD Speeds Control) 1202-1105 (24" Spinner Assy w/Lower Speeds Control) 1202-111 (30" Spinner Assy w/STD Speeds Control) 1202-110 (30" Spinner Assy w/Lower Speeds Control)	Adapter - Straight	1
30	1202-201 (STD Spinner Speeds Control) 1202-111 (Lower Spinner Speeds Control)	Adapter - Elbow Adapter - Straight	1
31	1202-110	Adapter - Straight	1
32	1202-1035	Adapter - Straight	1
33	1202-3015 (30" Spinner Assy)	Adapter - Tee	2
34	1211-603 (30" Spinner Assy)	Check Valve	1
35	1202-6516 (30" Spinner Assy)	Adapter - Straight	1
36	1207-132 (30" Spinner Assy)	Hose Ass'y	1

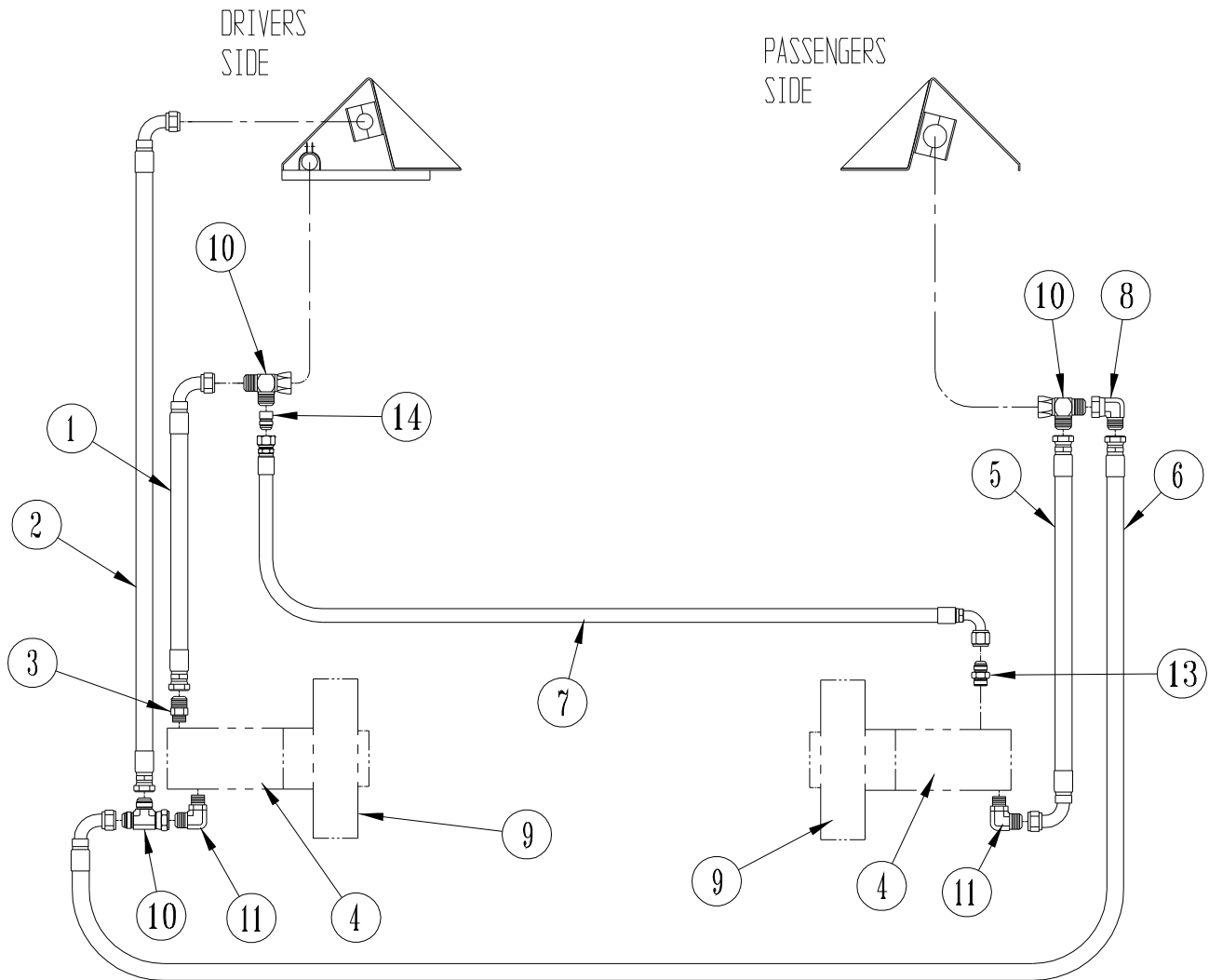

## ASPHALT CONVEYOR DRIVE HYDRAULICS

ITEM	PART NO.	DESCRIPTION	QTY.
1	1 207-041	Hose Ass'y	1
2	1 207-03	Hose Ass'y	1
3	1 202-111	Adapter - Straight	1
4		Motor - Hydraulic (See Pg. 1)	
5	1 207-062	Hose Ass'y	1
6	1 207-065	Hose Ass'y	1
7	1 207-0425	Hose Ass'y	1
8	1 202-200	Adapter - Elbow	1
9		Gear Box (See Pg. 1)	
10	1 202-3015	Adapter - Tee	3
11	1 202-204	Adapter - Elbow	2
12			
13	1 202-110	Adapter - Straight	1
14	1 202-1035	Adapter - Straight	1

## **OPTIONAL CAB SHIELD (102" WIDE BOXES)**

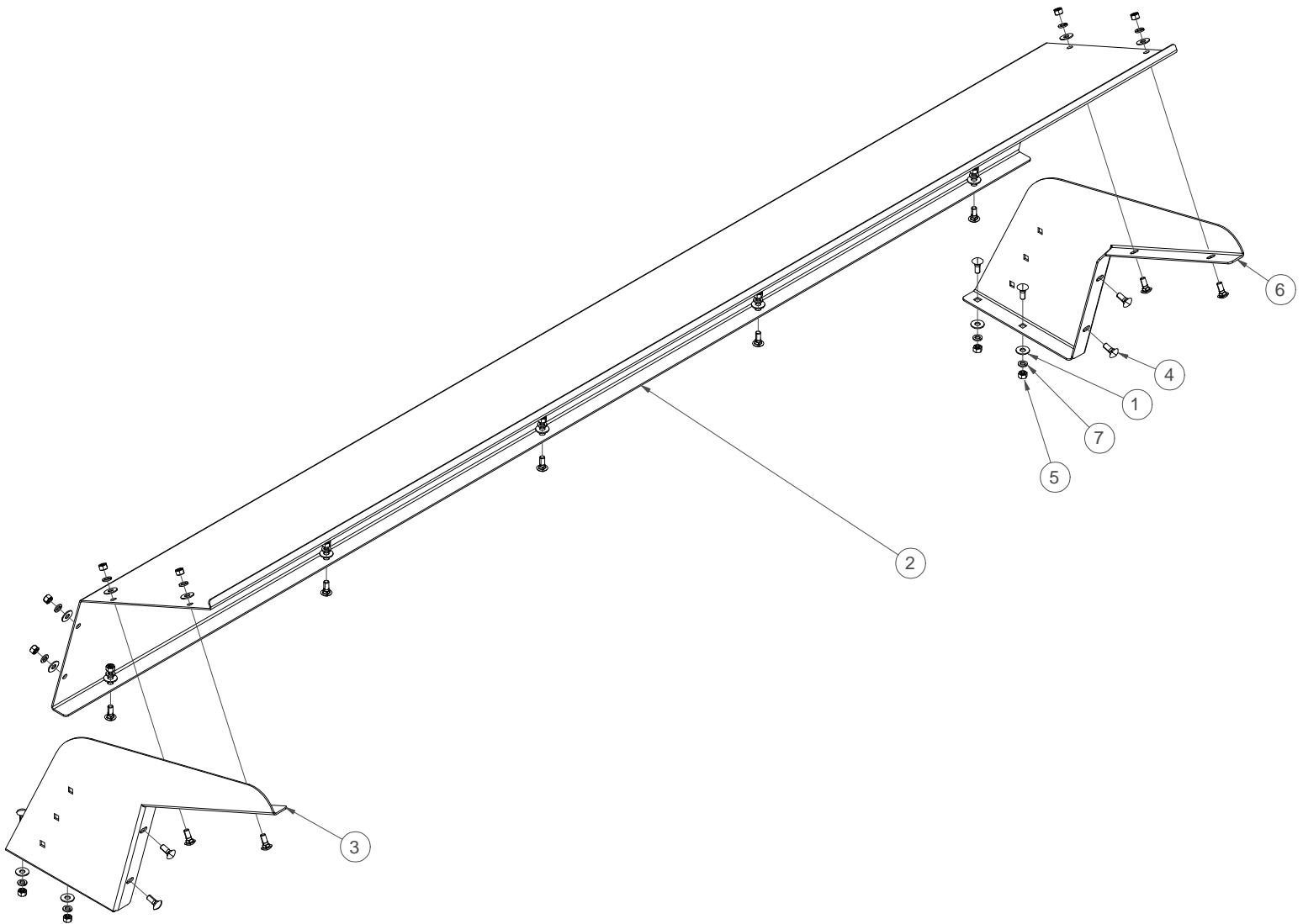

<b>ITEM</b>	<b>PART NO.</b>	<b>DESCRIPTION</b>	<b>QTY</b>
1	1209-41	Flat Washer - 3/8" SS	17
2	1234-501	SS Cab Shield - Center	1
3	1234-502 RH	SS Cab Shield - RH Side	1
4	1200-302SS	Carriage Bolt - 3/8" UNC x 1" SS	17
5	1205-27	Nut - 3/8" UNC SS	17
6	1234-502 LH	SS Cab Shield - LH Side	1
7	1209-43	Lock Washer - 3/8" SS	17

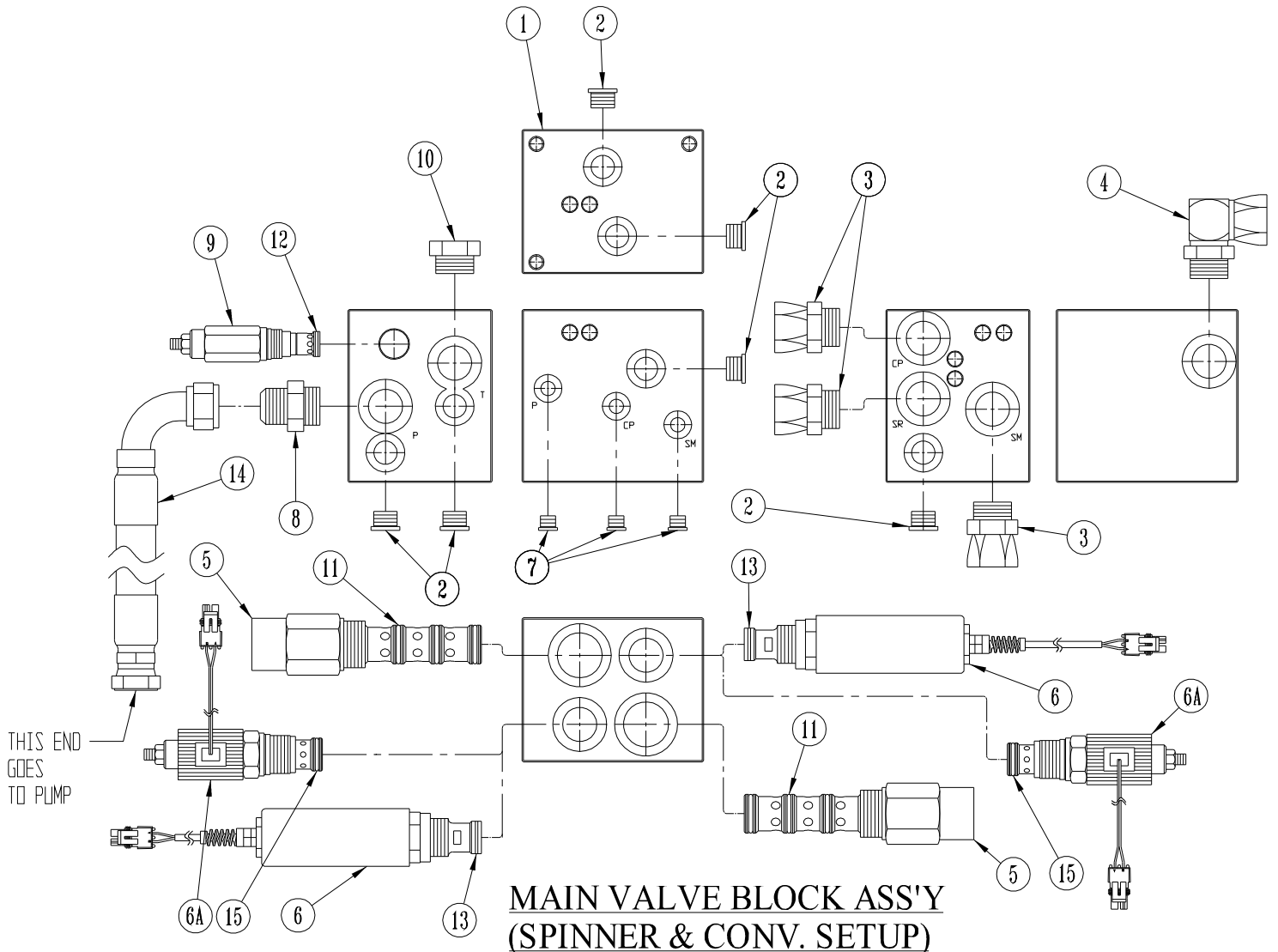

ITEM	PART NO.	DESCRIPTION	QTY
1	1211-00	Valve Block - Hydraulic Requires: 1200-400SS (3) Hex Head Capscrew - 1/2" UNC x 1" SS 1209-63 (3) Lock Washer - 1/2" SS	1
2	1202-119	Plug	6
3	1202-117	Adapter - Straight	3
4	1202-210	Adapter - Elbow	1
5	1211-80	Cartridge - PSI Compensator	2
6	1211-01 A	Valve - Hydraulic Servo	2
6A	1211-011 A	Valve - PWM	2
7	1202-118	Plug	3
8	1202-116	Adapter - Straight	1
9	1211-945	Valve - Hydraulic Relief	1
10	1202-120	Plug	1
11	1211-80K	Seal Kit	As Req'd
12	1211-95K	Seal Kit	As Req'd
13	1211-01 K	Seal Kit	As Req'd
14	1207-131	Hose Assy	1
15	1211-011SK	Seal Kit	1



## **Standard Main Valve Block Configuration**



Note: This page is for visual purposes only.

For Details Reference: Pg. 10 Main Block (Conveyor & Spinner Setup)

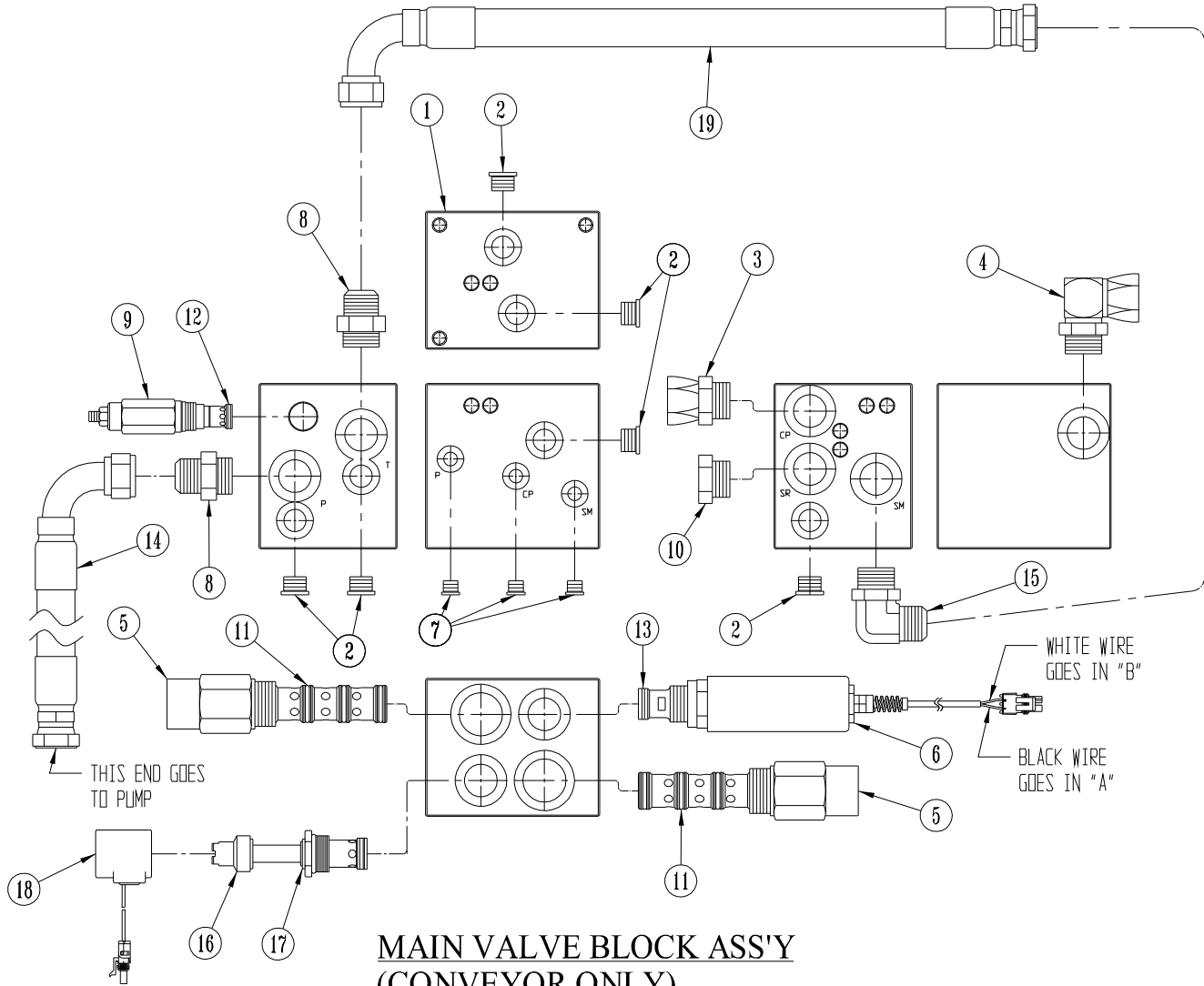

## MAIN VALVE BLOCK ASS'Y (CONVEYOR ONLY)

ITEM	PART NO.	DESCRIPTION	QTY
1	1 211-00	Valve Block - Hydraulic Requires: 1 200-400SS (3) Hex Head Capscrew - 1/2" UNC x 1" SS 1 209-63 (3) Lock Washer - 1/2" SS	1
2	1 202-119	Plug	6
3	1 202-117	Adapter - Straight	1
4	1 202-210	Adapter - Elbow	1
5	1 211-80	Cartridge - PSI Compensator	2
6	1 211-01 A	Valve - Hydraulic Servo	1
7	1 202-118	Plug	3
8	1 202-116	Adapter - Straight	2
9	1 211-95	Valve - Hydraulic Relief	1
10	1 202-120	Plug	1
11	1 211-80K	Seal Kit	As Req'd
12	1 211-95K	Seal Kit	As Req'd
13	1 211-01 K	Seal Kit	As Req'd
14	1 207-131	Hose Assy	1
15	1 202-201	Adapter - Elbow	1
16	1 222-110	Valve - Solenoid	1
17	1 222-110K	Seal Kit	As Req'd
18	1 222-110CA	Coil	1
19	1 207-001	Hose Assy	1

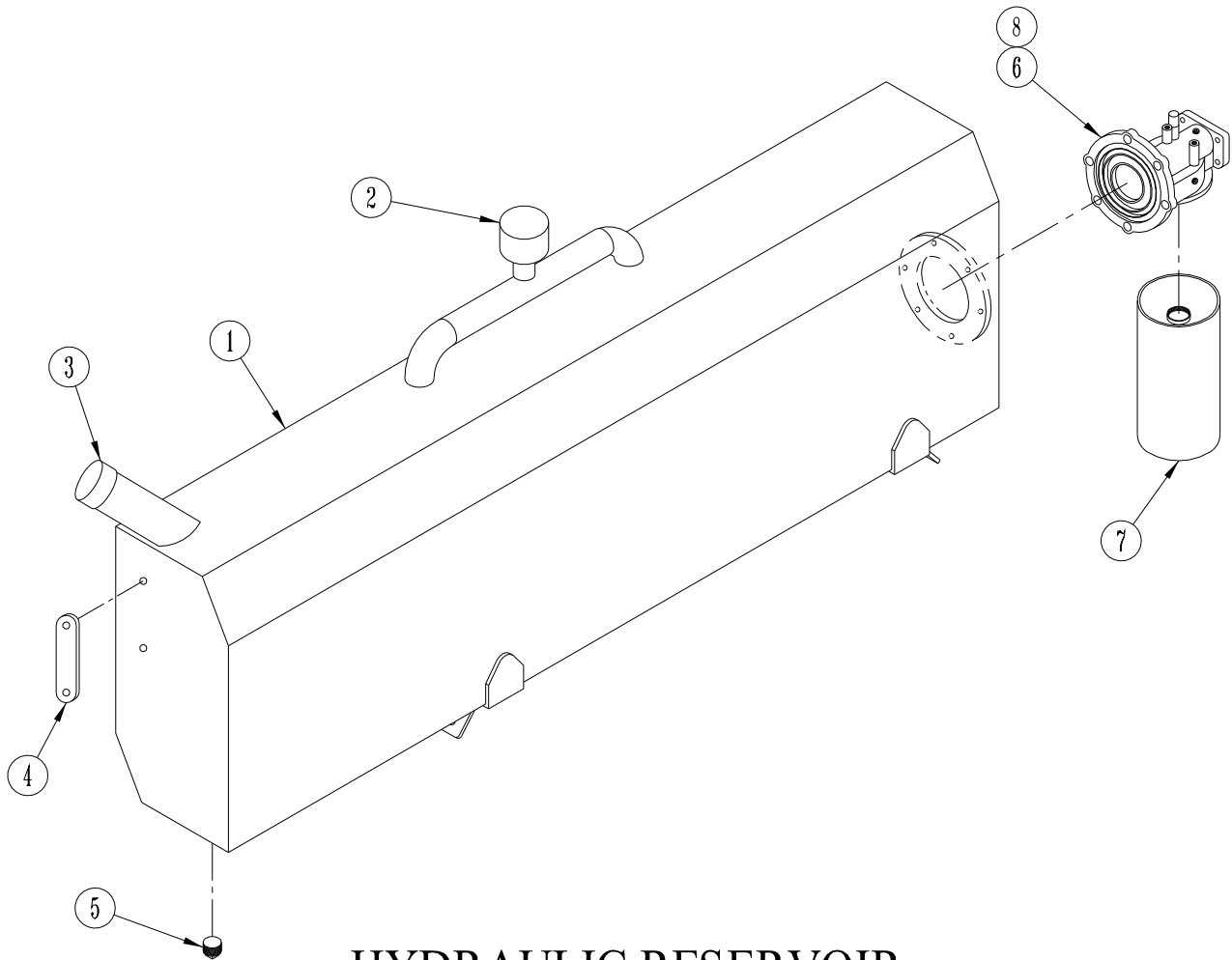

## HYDRAULIC RESERVOIR

<u>ITEM</u>	<u>PART NO.</u>	<u>DESCRIPTION</u>	<u>QTY</u>
1	1236-201	Weldment - SS Reservoir, Hydraulic	1
1	1236-201 MS	Weldment - MS Reservoir, Hydraulic	1
	1200-4011	Requires: (4) Hex Head Cap Screw - 1/2" UNC x 1-1/4" SS	
	1205-36	(4) Nut - 1/2" UNC SS	
	1209-63	(4) Lock Washer - 1/2" SS	
		Per Tank	
2	1220-34	Breather - Reservoir	1
3	1220-475	Cap - Fill	1
4	1221-9	Guage - Sight	1
5	1201-239	Plug - SS	1
6	1100-195	Housing - Filter	1
7	1220-37	Element - Filter	1
8	1100-195K	Seal Kit - Filter Housing	1

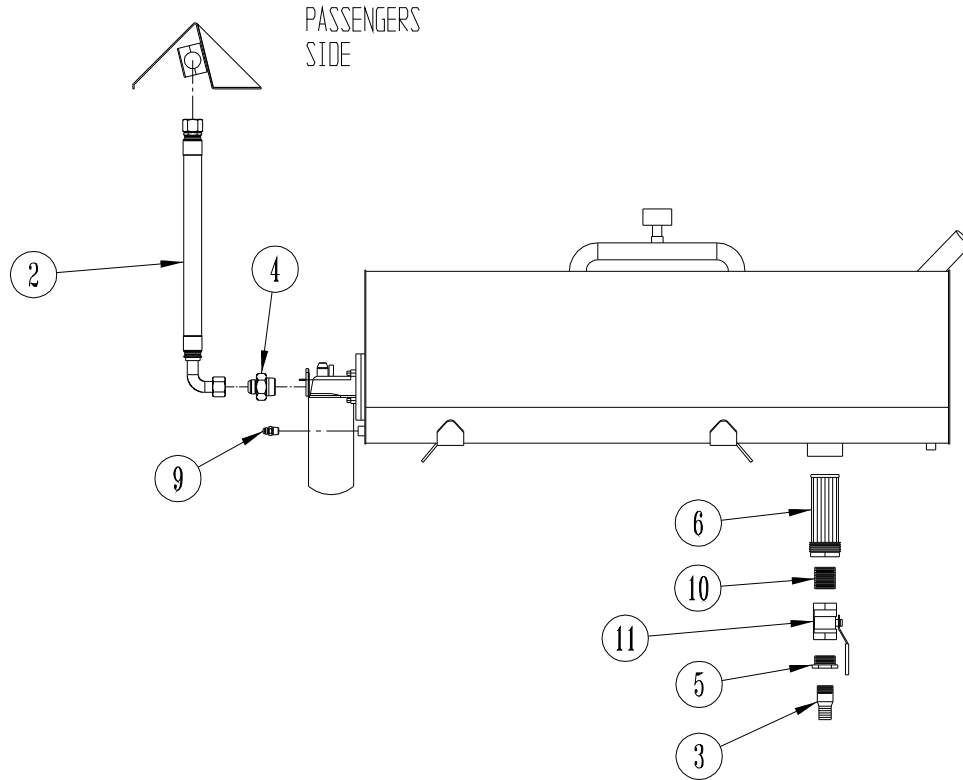

## RESERVOIR/PUMP HYDRAULICS

ITEM	PART NO.	DESCRIPTION	QTY.
1			
2	1 207-027	Hose - Hydraulic, Return	1
3	1 201-189	Nipple - King, SS	1
4	1 202-1027	Adapter - Straight	1
5	1 201-296	Bushing - Reducer, SS	1
6	1 220-36	Strainer - Suction	1
7			
8			
9	1 202-1003	Adapter - Straight	1
10	1 201-288	Optional Nipple - Close, SS (req'd w/opt. shutoff valve)	1
11	1 211-13	Optional Valve - Shutoff, SS	1

## **PRO-FORCE FULL FLOAT FENDERS AND MUDFLAPS**

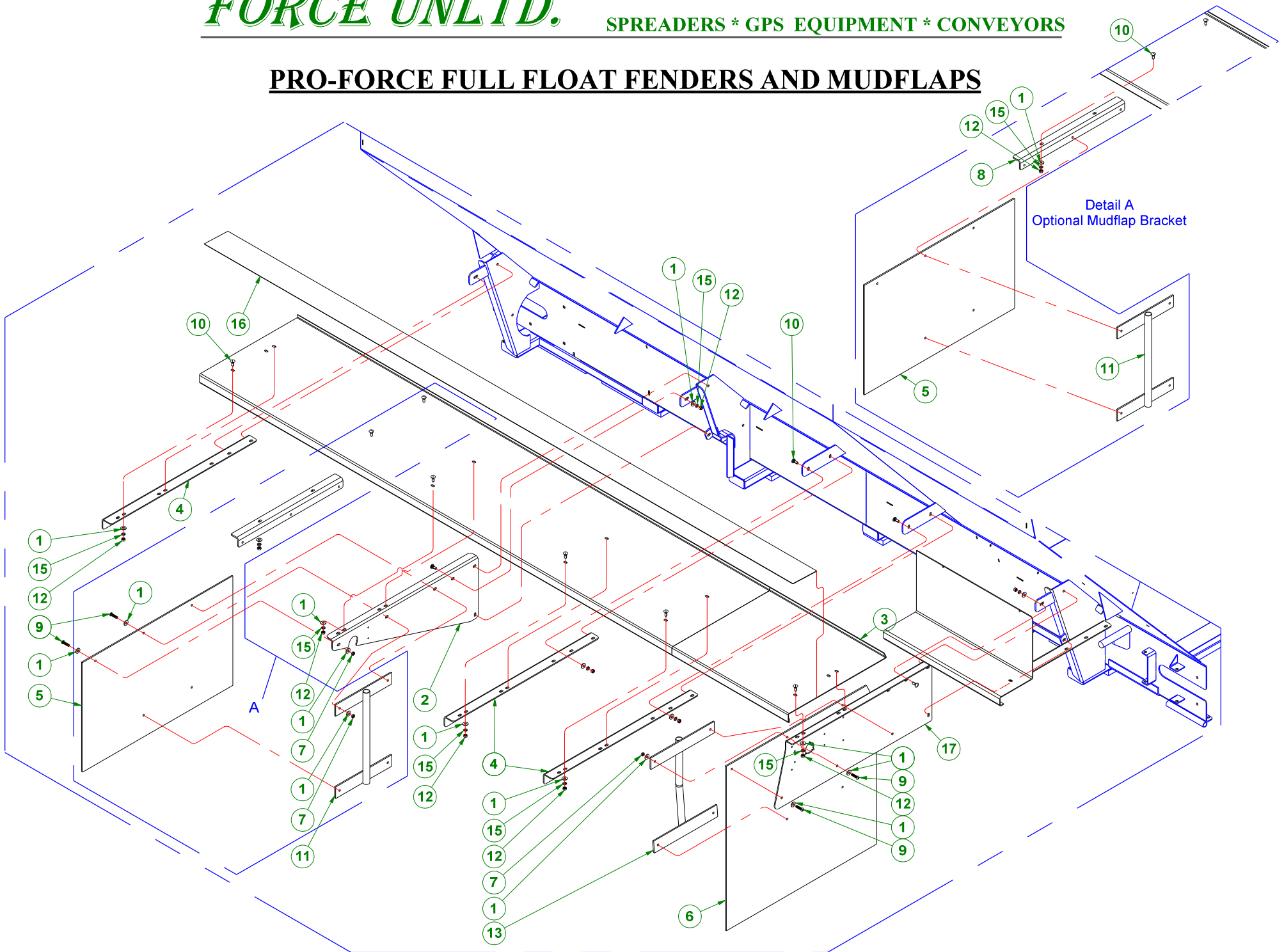

**PRO-FORCE FULL FLOAT FENDERS AND MUDFLAPS**

<b>ITEM</b>	<b>PART NO.</b>	<b>DESCRIPTION</b>	<b>QTY</b>
1	1209-41	Flat Washer - 3/8" SS	As Req'd
2	1234-603	Middle Fender Bracket (Used on 13', 14', 15', 18', 20'-24')	1 RH, 1 LH
3	1234-614	Full Float Fender - Specify Length of Box & MS or SS	1 RH, 1 LH
4	1234-604	Fender Mounting Angle	As Req'd
5	F 3238P	Mudflap - 38" x 24"	1 RH, 1 LH
6	F 3844P	Mudflap - 38" x 36"	1 RH, 1 LH
7	1205-26	Nylon Lock Nut - 3/8" UNC SS	As Req'd
8	F 3238PBA	Optional Mudflap Bracket (for mounting mudflap farther ahead than the standard location)	2
9	1200-3047	Button Head Capscrew - 3/8" UNC x 1 1/2" SS	As Req'd
10	1200-302SS	Carriage Bolt - 3/8" UNC x 1" SS	As Req'd
11	F 3238PB	Front Mudflap Bracket	2
12	1205-27	Nut - 3/8" UNC SS	As Req'd
13	F 3844PB	Rear Mudflap Bracket	2
15	1209-43	Lock Washer - 3/8" SS	As Req'd
16	1234-702	Safety Walk	As Req'd
17	1234-602	Rear Fender Bracket	1 RH, 1 LH

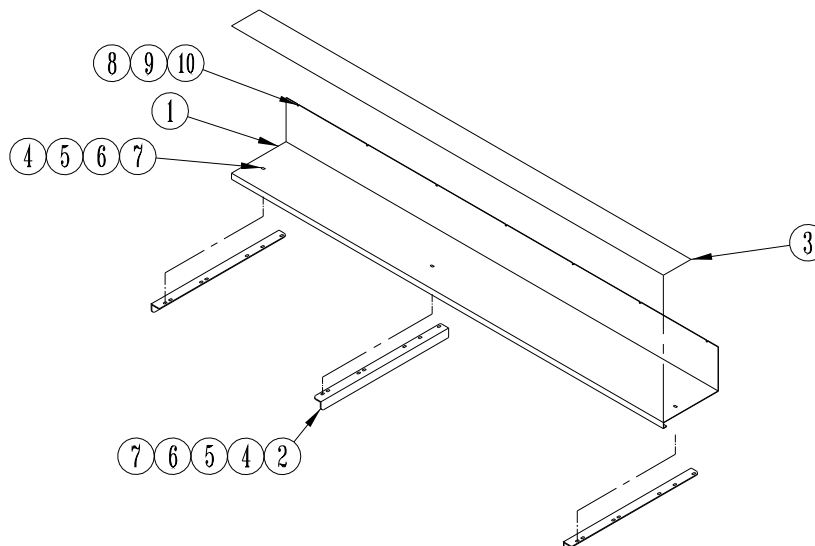

### SEMI FLOAT FENDERS AND BRACKETS

ITEM	PART NO.	DESCRIPTION	QTY.
1	1234-712 1234-712MS	SS Semi Float Fender - 12' MS Semi Float Fender - 12'	1 RH, 1 LH
1	1234-713 1234-713MS	SS Semi Float Fender - 13' MS Semi Float Fender - 13'	1 RH, 1 LH
1	1234-714 1234-714MS	SS Semi Float Fender - 14' MS Semi Float Fender - 14'	1 RH, 1 LH
1	1236-716 1236-716MS	SS Semi Float Fender - 16' MS Semi Float Fender - 16'	1 RH, 1 LH
1	1236-717 1236-717MS	SS Semi Float Fender - 17' MS Semi Float Fender - 17'	1 RH, 1 LH
1	1236-718 1236-718MS	SS Semi Float Fender - 18' MS Semi Float Fender - 18'	1 RH, 1 LH
1	1236-720 1236-720MS	SS Semi Float Fender - 20' MS Semi Float Fender - 20'	1 RH, 1 LH
1	1236-721 1236-721 MS	SS Semi Float Fender - 21' MS Semi Float Fender - 21'	1 RH, 1 LH
1	1236-722 1236-722MS	SS Semi Float Fender - 22' MS Semi Float Fender - 22'	1 RH, 1 LH
1	1236-723 1236-723MS	SS Semi Float Fender - 23' MS Semi Float Fender - 23'	1 RH, 1 LH
1	1236-724 1236-724MS	SS Semi Float Fender - 24' MS Semi Float Fender - 24'	1 RH, 1 LH
2	1234-604	Fender Mounting Angle	As Req'd
3	1234-702	Safety Walk	As Req'd
4	1209-43	Lock Washer - 3/8" SS	As Req'd
5	1205-27	Nut - 3/8" UNC SS	As Req'd
6	1200-302SS	Carriage Bolt - 3/8" UNC x 1" SS	As Req'd
7	1209-41	Flat Washer - 3/8" SS	As Req'd
8	1200-105	Hex Head Cap Screw - 1/4" UNC x 3/4" SS	As Req'd
9	1209-25S	Flat Washer - 1/4" SS	2 Per Item #8
10	1205-501	Lock Nut - 1/4" UNC SS	As Req'd

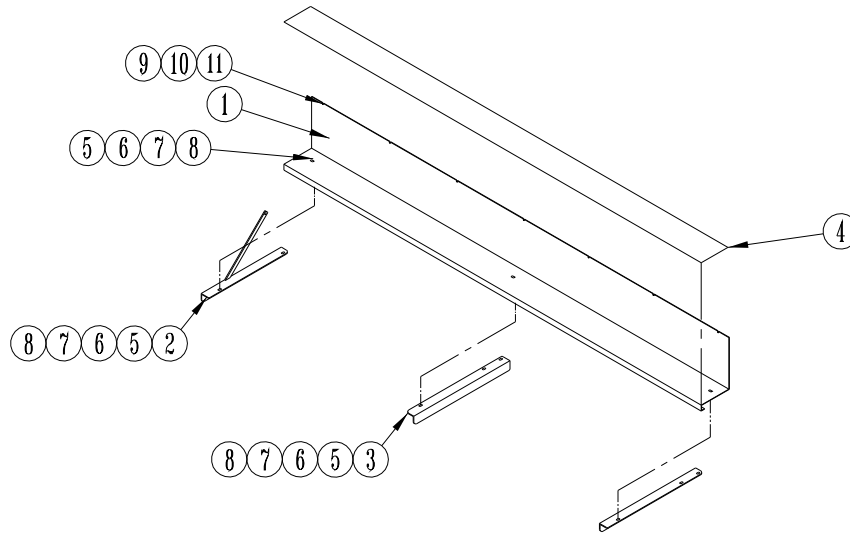

## TRUCK TIRE FENDERS AND BRACKETS

ITEM	PART NO.	DESCRIPTION	QTY.
1	1234-812 1234-812MS	SS Truck Tire Fender - 12' MS Truck Tire Fender - 12'	1 RH, 1 LH
1	1234-813 1234-813MS	SS Truck Tire Fender - 13' MS Truck Tire Fender - 13'	1 RH, 1 LH
1	1234-814 1234-814MS	SS Truck Tire Fender - 14' MS Truck Tire Fender - 14'	1 RH, 1 LH
1	1236-816 1236-816MS	SS Truck Tire Fender - 16' MS Truck Tire Fender - 16'	1 RH, 1 LH
1	1236-817 1236-817MS	SS Truck Tire Fender - 17' MS Truck Tire Fender - 17'	1 RH, 1 LH
1	1236-818 1236-818MS	SS Truck Tire Fender - 18' MS Truck Tire Fender - 18'	1 RH, 1 LH
1	1236-820 1236-820MS	SS Truck Tire Fender - 20' MS Truck Tire Fender - 20'	1 RH, 1 LH
1	1236-821 1236-821MS	SS Truck Tire Fender - 21' MS Truck Tire Fender - 21'	1 RH, 1 LH
1	1236-822 1236-822MS	SS Truck Tire Fender - 22' MS Truck Tire Fender - 22'	1 RH, 1 LH
1	1236-823 1236-823MS	SS Truck Tire Fender - 23' MS Truck Tire Fender - 23'	1 RH, 1 LH
1	1236-824 1236-824MS	SS Truck Tire Fender - 24' MS Truck Tire Fender - 24'	1 RH, 1 LH
2	1236-603RH	Weldment - Fender Mounting Angle	As Req'd
2	1236-603LH	Weldment - Fender Mounting Angle	As Req'd
3	1236-604	Fender Mounting Angle	As Req'd
4	1234-702	Safety Walk	As Req'd
5	1209-43	Lock Washer - 3/8" SS	As Req'd
6	1205-27	Nut - 3/8" UNC SS	As Req'd
7	1200-302SS	Carriage Bolt - 3/8" UNC x 1" SS	As Req'd
8	1209-41	Flat Washer - 3/8" SS	As Req'd
9	1200-105	Hex Head Cap Screw - 1/4" UNC x 3/4" SS	As Req'd
10	1209-25S	Flat Washer - 1/4" SS	2 Per Item #9
11	1205-501	Lock Nut - 1/4" UNC SS	As Req'd



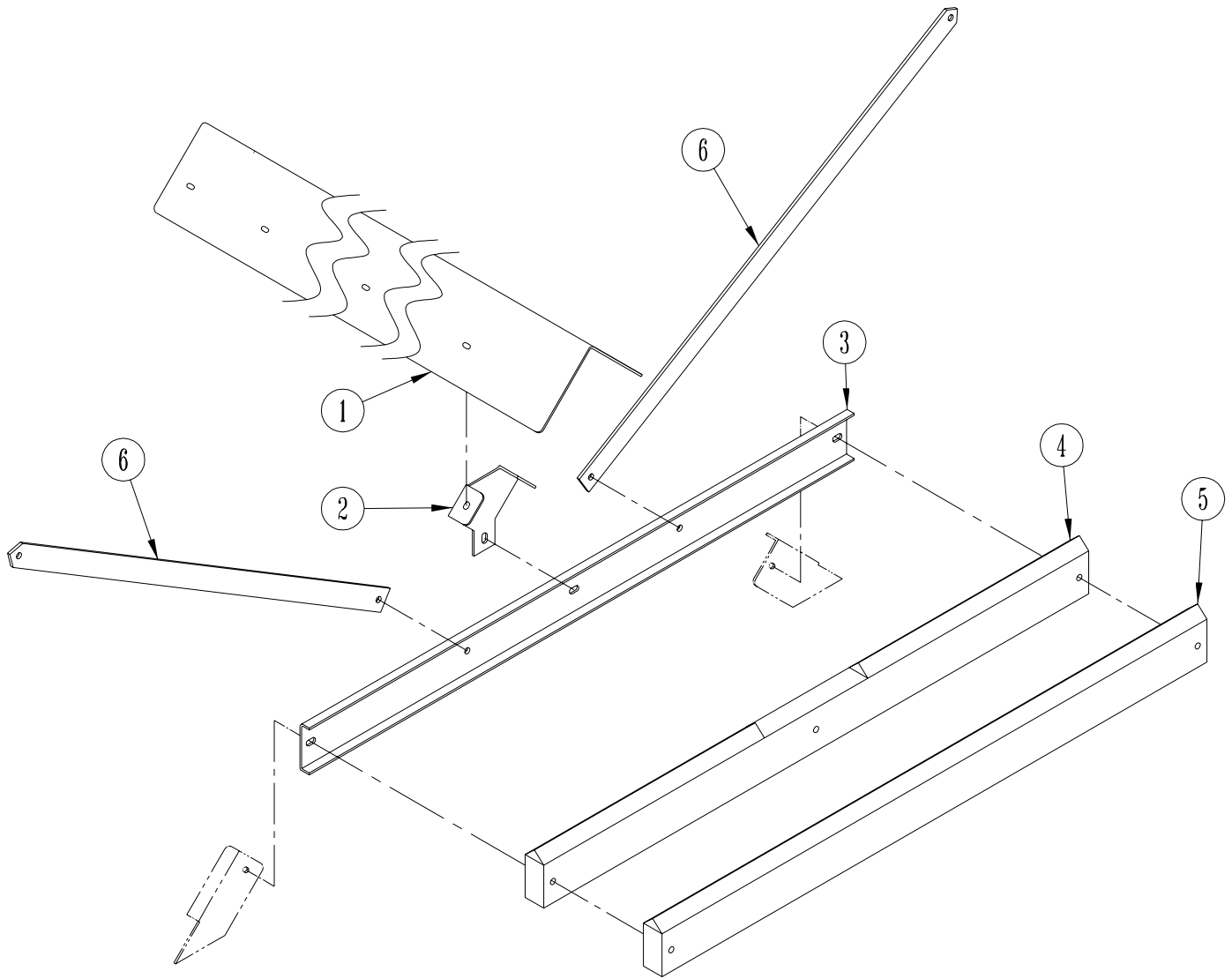

**INVERTED "V" & CROSS BRACE ASSEMBLY**

ITEM	PART NO.	DESCRIPTION	QTY
1	1234-105 1234-105MS 1236-1055  1236-1055MS  1200-302SS 1205-27 1209-41 1209-43	SS Inverted "V" (12'-16' Box Lengths, 102" Wide) MS Inverted "V" (12'-16' Box Lengths, 102" Wide) SS Inverted "V" (12'-18' Box Lengths, 90" Wide) (18'-28' Box Lengths, 102" Wide) MS Inverted "V" (12'-18' Box Lengths, 90" Wide) (18'-28' Box Lengths, 102" Wide)  Requires: (2) Carriage Bolt - 3/8" UNC X 1" Lg. SS (2) Nut - 3/8" SS (2) Flat Washer - 3/8" SS (2) Lock Washer - 3/8" SS  Per 1234-106 OR 1234-106MS (Inverted "V" Bracket)	1
2	1234-106 1234-106MS  1200-401 or 1200-412  1205-36 1209-61 1209-63	Bracket - SS Inverted "V" Bracket - MS Inverted "V" Requires: (1) Carriage Bolt - 1/2" UNC X 1 1/4" Lg. SS or Hex Head Capscrew - 1/2" UNC x 3" Lg. for use w/Asphalt style cross braces (1) Nut - 1/2" SS (1) Flat Washer - 1/2" SS (1) Lock Washer - 1/2" SS  Per Bracket	2
3	1234-107 1234-107MS  1200-401 1205-36 1209-61 1209-63	Cross Brace - SS Cross Brace - MS Requires: (2) Carriage Bolt - 1/2" UNC X 1 1/4" Lg. SS (2) Nut - 1/2" SS (2) Flat Washer - 1/2" SS (2) Lock Washer - 1/2" SS  Per Cross Brace	2 (12'-16' Box Lengths, 90" Wide) 3 (16'-18' Box Lengths, 90" Wide) 3 (18' Box Lengths, 102" Wide) 4 (20'-22' Box Lengths, 102" Wide) 5 (23', 24' & 26' Box Lengths, 102" Wide) 6 (28' Box Lengths, 102" Wide)
4	1236-107  1200-412 1205-36 1209-61 1209-63	Front Cross Brace Weldment - Asphalt Unit Requires: (2) Hex Head Capscrew - 1/2" UNC X 3" Lg. (2) Nut - 1/2" SS (2) Flat Washer - 1/2" SS (2) Lock Washer - 1/2" SS  Per Cross Brace	2 (16'-18' Box Lengths, Asphalt Unit) 3 (21' Box Lengths, Asphalt Unit)
5	1236-107-2  1200-412 1205-36 1209-61 1209-63	Rear Cross Brace Weldment - Asphalt Unit Requires: (2) Hex Head Capscrew - 1/2" UNC X 3" Lg. (2) Nut - 1/2" SS (2) Flat Washer - 1/2" SS (2) Lock Washer - 1/2" SS  Per Cross Brace	1 (Per Asphalt Unit)
6	1236-106 1236-106 MS 1236-1061 1236-1061 MS  1200-412 1200-3011 1205-36 1209-61 1209-63	Side Panel Brace for SS 102" Wide Pro-Force Side Panel Brace for MS 102" Wide Pro-Force Side Panel Brace for SS 90" Wide Pro-Force Side Panel Brace for MS 90" Wide Pro-Force Requires: (1) Hex Head Capscrew - 3/8" UNC X 3" Lg. (1) Hex Head Capscrew - 3/8" UNC X 1" Lg. SS (2) Nut - 3/8" SS (2) Flat Washer - 3/8" SS (2) Lock Washer - 3/8" SS  Per Brace	2 Per 16' & 17' Pro-Force 4 Per 18' - 26' Pro-Force 6 Per 28' Pro-Force

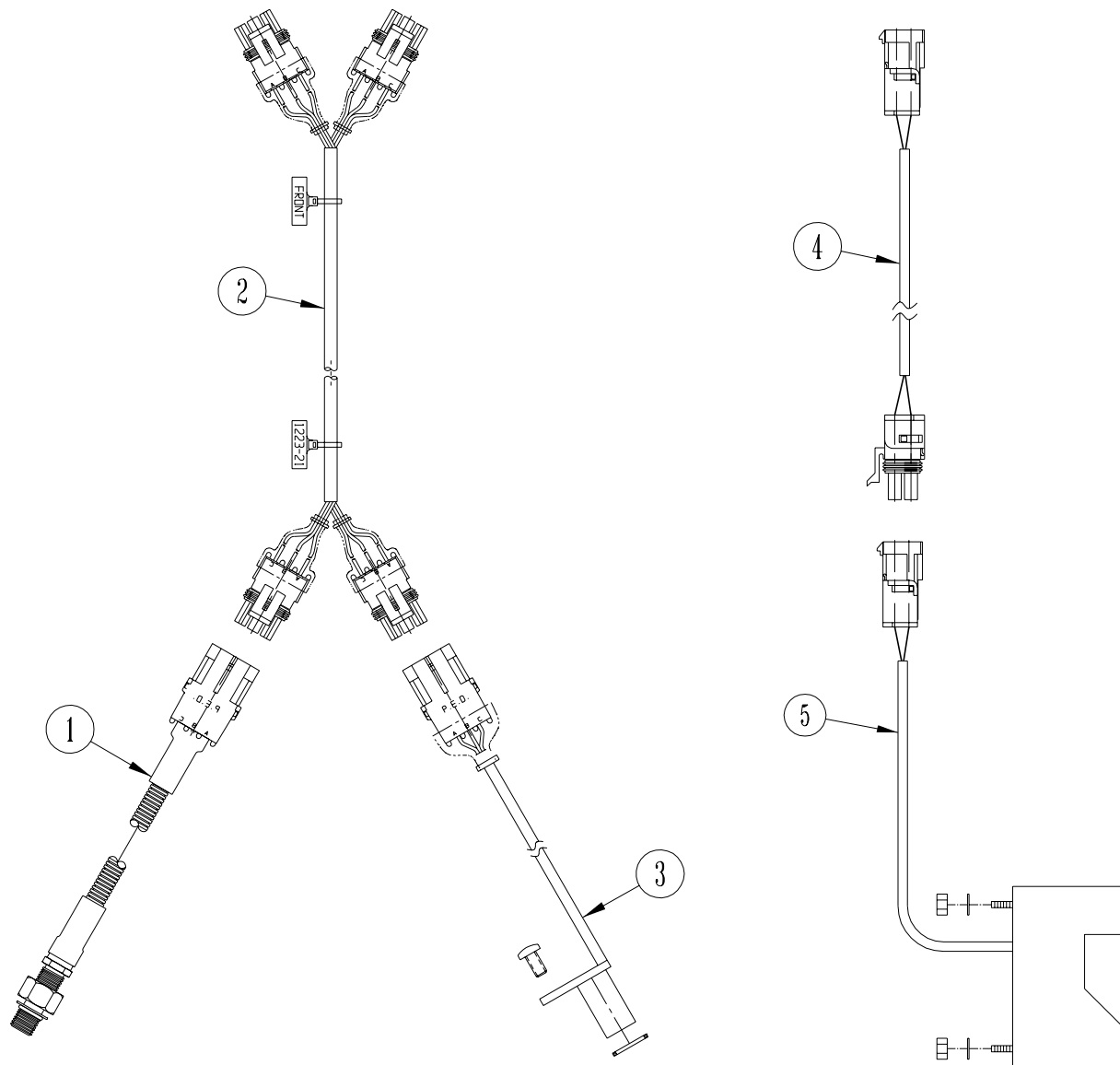

## SENSOR WIRING HARNESS

ITEM	PART NO.	DESCRIPTION	QTY
1	1223-600	Sensor - Conveyor Speed	1
2	1223-21	Cable Assy - Sensor	1
3	1223-22	Sensor - Hub Assy	1
4	1223-829	Optional Cable - Ass'y Bin Level	1
5	1223-64	Optional Sensor - Bin Level	1

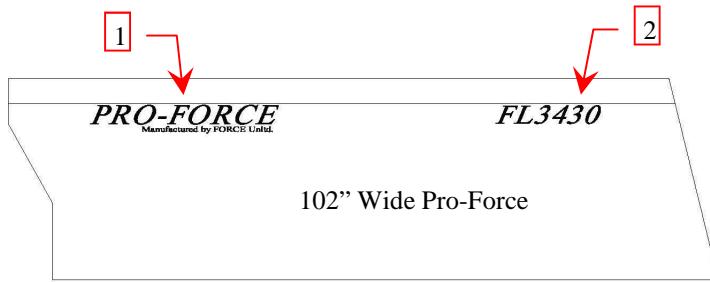

Front

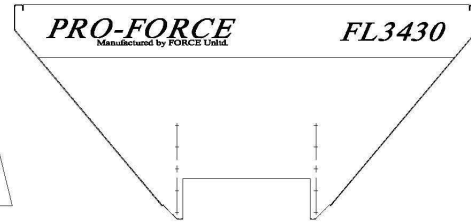

Rear

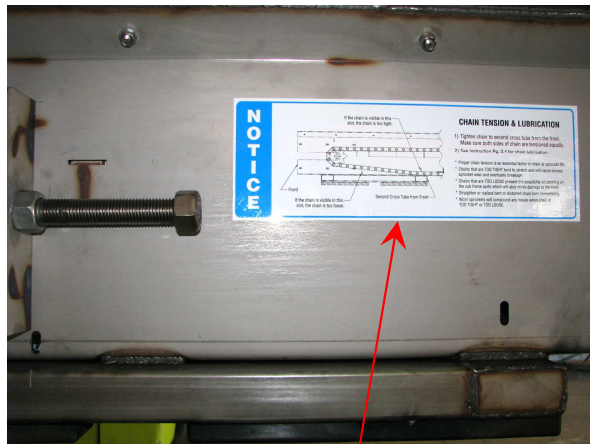
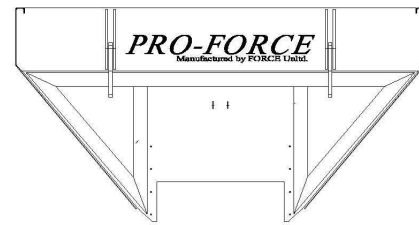
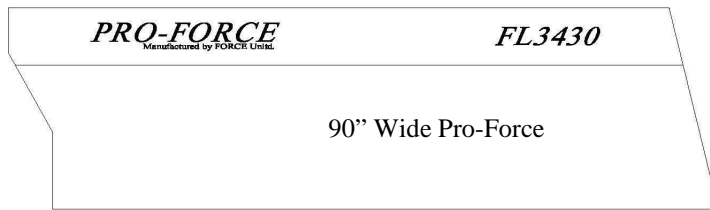

3



4

## Decals

<u>ITEM</u>	<u>PART NO.</u>	<u>DESCRIPTION</u>	<u>SWINGING ENDGATE QTY'S</u>	<u>SOLID REAR PANEL QTY'S</u>
1	1236-060	Decal, PRO-FORCE (Red)	3	3
	1236-060 B	Decal, PRO-FORCE (Black)	3	3
	1236-060W	Decal, PRO-FORCE (White)	3	3
2	1236-041	Decal - FL3430 (Red)	2	3
	1236-041 B	Decal - FL3430 (Black)	2	3
	1236-041 W	Decal - FL3430 (White)	2	3
3	1234-055	Decal - Chain Tension	1	1
4	1234-056	Decal - Hydraulic Oil	1	1

## GEAR BOX

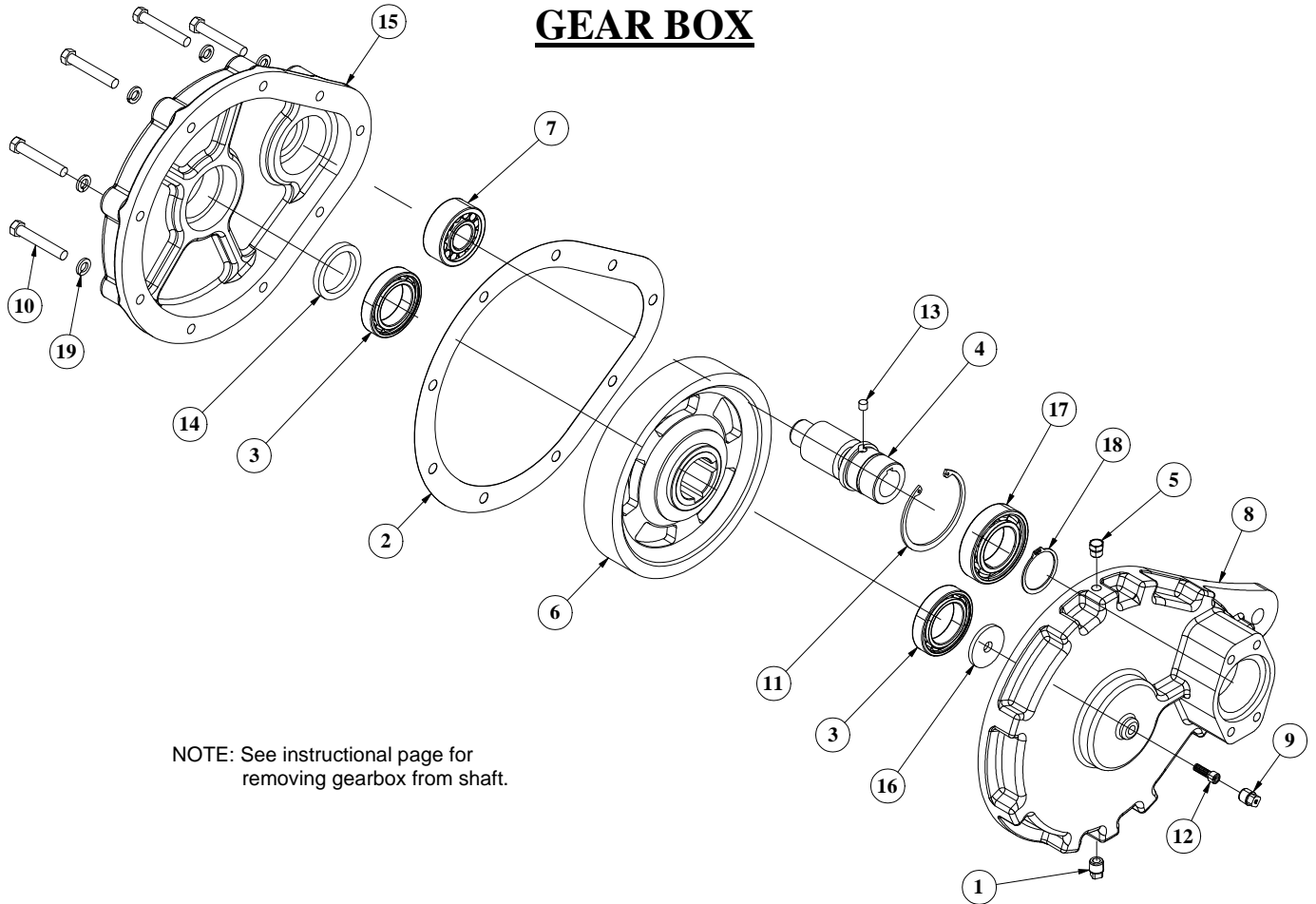

NOTE: See instructional page for removing gearbox from shaft.

ITEM	PART NO.	DESCRIPTION	QTY
1	1201-238M	Plug - 1/2" Square Head, Magnetic	1
2	1204-08	Gasket	1
3	1217-104	Bearing	2
4	1217-110	Gear - Pinion	1
5	1220-501	Breather	1
6	1217-111	Gear - Driven	1
7	1217-105	Bearing - Small - Pinion Nose	1
8	1220-50-O	Housing - Outboard, Gearbox	1
9	1201-238	Plug - 1/2" Square Head	1
10	1200-327	Hex Head Capscrew - 7/16" UNC x 2 3/4"	9
11	1208-97	Snap Ring	1
12	1200-251A	Capscrew - Socket Head 5/16-18 x 1"	1
13	1217-110P	Plug - Delrin	1
14	1204-07	Seal	1
15	1220-50-I	Housing - Inboard, Gearbox	1
16	1209-100	Washer - Retainer	1
17	1217-106	Bearing - Large - Pinion Shaft	1
18	1208-06	Snap Ring	1
19	1209-102	Lock Washer - 7/16"	9

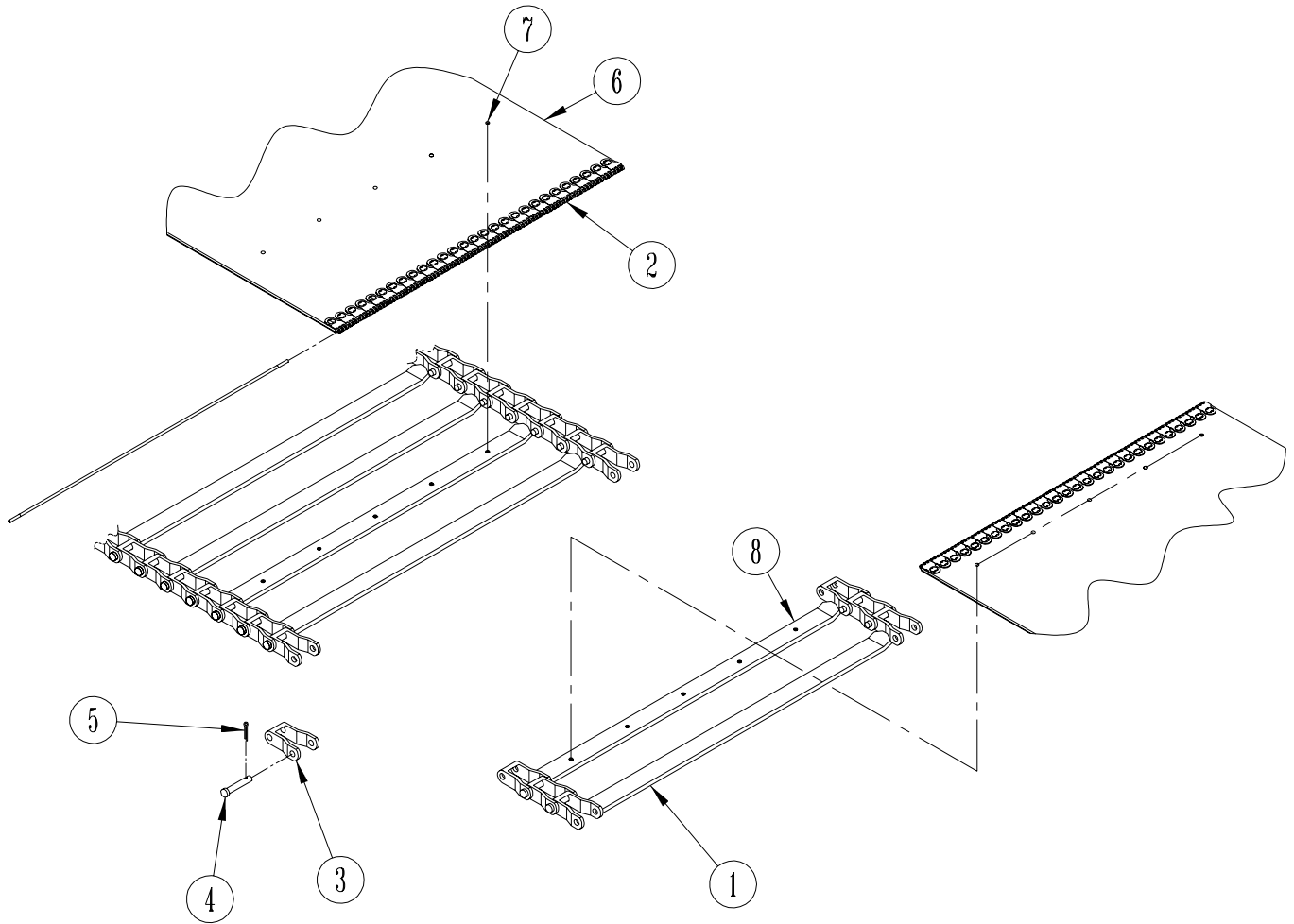

## **BELT OVER PINTLE CHAIN**

<b><u>ITEM</u></b>	<b><u>PART NO.</u></b>	<b><u>DESCRIPTION</u></b>	<b><u>QTY.</u></b>
1	1 236-907	Weldment - Crossbar (without holes)	As Req'd
2	1 000-42 1 000-43	Splice Kit - M/S Splice Kit - S/S	1
3	1 234-901	Link - Pintle Chain	As Req'd
4	1 234-902	Pin - Pintle Chain	As Req'd
5	1 234-903	Cotter Pin	As Req'd
6	1 000-29 1 000-29TK	Belt - Conveyor (Specify Box Length) High Temp. Belt - Conveyor (Specify Box Length)	As Req'd As Req'd
7	1 209-40C 1 209-41C 1 200-248 1 200-249 1 200-251 5	Washer - Dimpled M/S Washer - Dimpled S/S Allen Head Cap Screw - Alloy Steel Allen Head Cap Screw - Stainless Steel Allen Head Cap Screw - Alloy Steel (Used on High Temp BOC only)	As Req'd
8	1 236-908	Weldment - Crossbar (with holes)	As Req'd

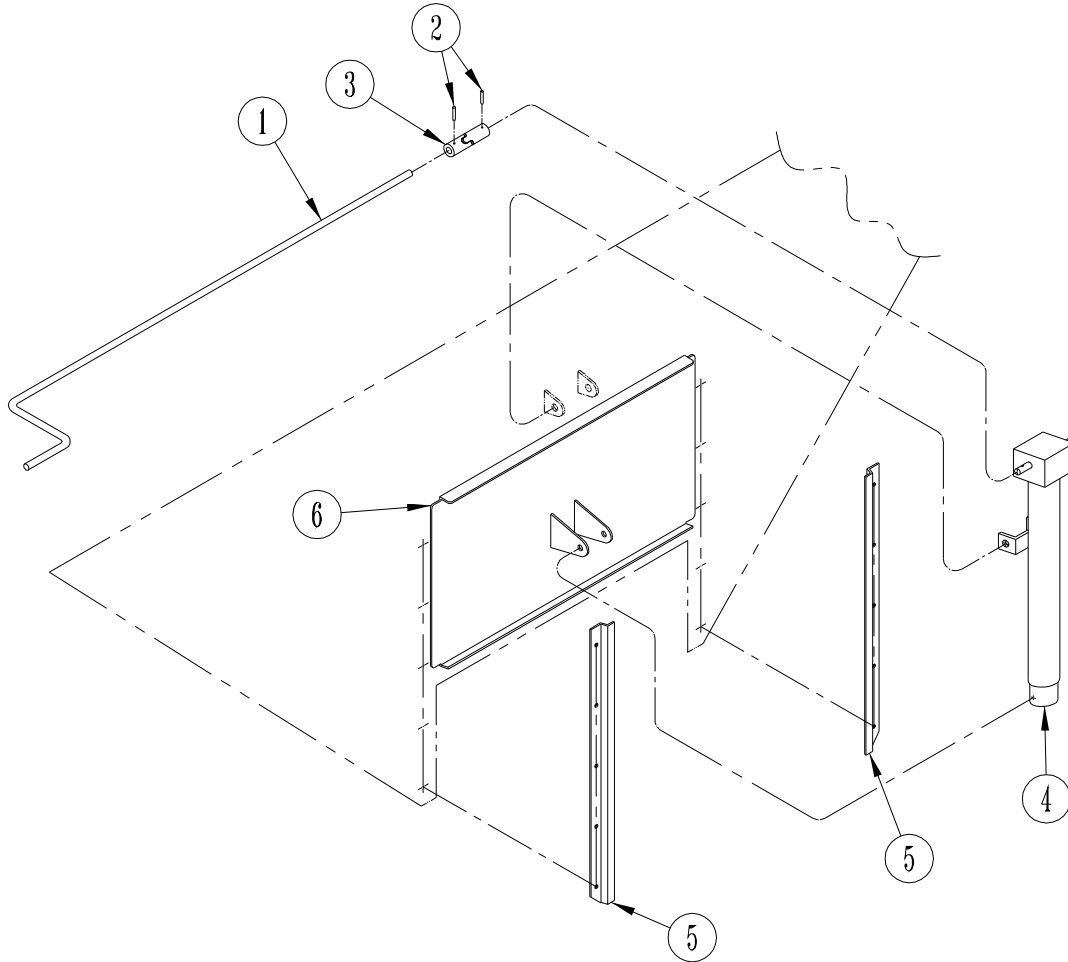

## FEEDGATE ASSEMBLY w/SOLID REAR PANEL

ITEM	PART NO.	DESCRIPTION	QTY
1	1218-81 1218-81SS	Handle- MS Handle- SS	1
2	1208-015	Roll Pin	2
3	1218-85	U-Joint	1
4	1218-80  1200-310 1209-42 1205-21  1200-416 1209-62 1205-37	Assembly - Jack Lower Tab Requires: (1) Hex Head Capscrew - 3/8" UNC x 3" MS (1) Lock Washer - 3/8" MS (1) Nut - 3/8" UNC MS Upper Tab Requires: (1) Hex Head Capscrew - 1/2" UNC x 4" MS (1) Lock Washer - 1/2" MS (1) Nut - 1/2" UNC MS	1
5	1218-86	SS Slides - Feedgate	1-RH, 1-LH
5	1218-86MS  1200-202 1209-22 1205-11	MS Slides - Feedgate Requires (Per Slide): (5) Hex Head Capscrew - 1/4" UNC x 1" SS (5) Lock Washer - 1/4" SS (5) Nut - 1/4" UNC SS	1-RH, 1-LH
6	1236-350	Weldment - SS Feedgate	1
6	1236-350MS	Weldment - MS Feedgate	1

## SWINGING ENDGATE & FEEDGATE ASSEMBLY

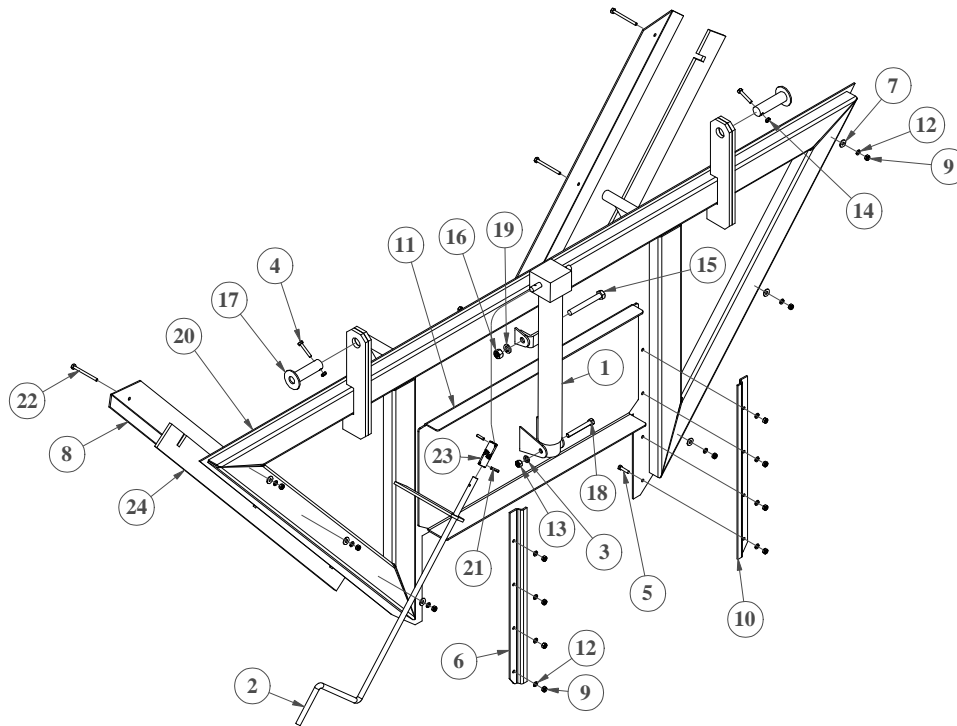

ITEM	PART NO.	DESCRIPTION	QTY
1	1218-80	Assembly - Jack	1
2	1218-81S	Handle (Specify material)	1
3	1209-42	Lock Washer - 3/8"	1
4	1200-2049	Hex Head Cap Screw - 1/4" UNC x 1 1/2" SS	2
5	1200-202	Hex Head Capscrew - 1/4" UNC x 1" Lg. SS	8
6	1218-86S LH	Feedgate Slide - LH (Specify material)	1
7	1209-25S	Flat Washer - 1/4" SS	6
8	1236-652	Swinging Endgate Seal Strip Pinch Plate (Specify material)	2
9	1205-11	Nut - 1/4" UNC SS	14
10	1218-86S RH	Feedgate Slide - RH (Specify material)	1
11	1236-350S	Weldment - Feedgate (Specify material & if it is reinforced)	1
12	1209-22	Lock Washer - 1/4" SS	14
13	1205-21	Nut - 3/8" UNC	1
14	1205-501	Lock Nut - 1/4" UNC SS	2
15	1200-416	Hex Head Capscrew - 1/2" UNC x 4"	1
16	1205-37	Nut - 1/2" UNC	1
17	1236-651	Weldment - Pin, (Specify material)	2
18	1200-310	Hex Head Capscrew - 3/8" UNC x 3" MS	1
19	1209-62	Lock Washer - 1/2"	1
20	1236-650	Weldment - Swinging Endgate (Specify material)	1
21	1208-015	Roll Pin	2
22	1200-212	Hex Head Cap Screw - 1/4" UNC x 3" SS	6
23	1218-85	U-Joint	1
24	1236-653	Swinging Endgate Seal Strip (Specify standard or high temp)	2



## SWINGING ENDGATE CATCH/RELEASE ASSEMBLY

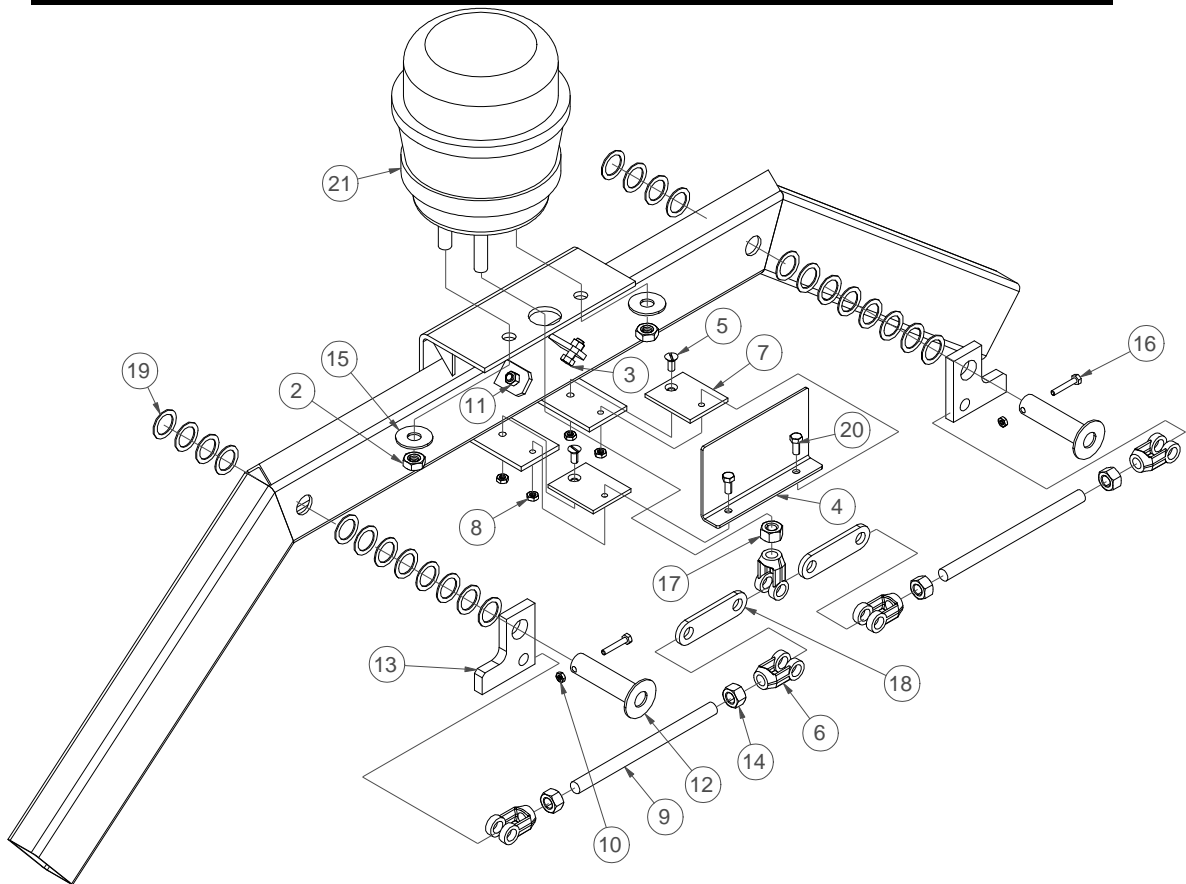

ITEM	PART NO.	DESCRIPTION	QTY
2	1205-47	Lock Nut - 5/8" UNC	2
3	1200-301	Hex Head Cap Screw - 3/8" UNC x 1"	2
4	1236-354	Linkage Guide Plate	1
5	1200-248	Flat Head Cap Screw - 5/16" UNC x 3/4"	2
6	1208-04	Yoke Kit	5
7	1236-351	Linkage Slide Surface	2
8	1205-17	Lock Nut - 5/16" UNC	4
9	1225-05	Adjusting Rod	2
10	1205-10	Lock Nut - 1/4" UNC	2
11	1205-21	Nut - 3/8" UNC	2
12	1208-025	Pin	2
13	1236-353	Door Catch	2
14	1205-52	Nut - 5/8" UNF	4
15	1209-70	Flat Washer - 5/8" MS	2
16	1200-205	Hex Head Cap Screw - 1/4" UNC x 1 1/2"	2
17	1205-51	Nut - 5/8" UNC MS	1
18	1236-352	Linkage	2
19	1209-96	Machinery Washer - 1"	24
20	1200-250	Hex Head Cap Screw - 5/16" UNC x 3/4"	2
21	1222-02	Air Brake Actuator	1

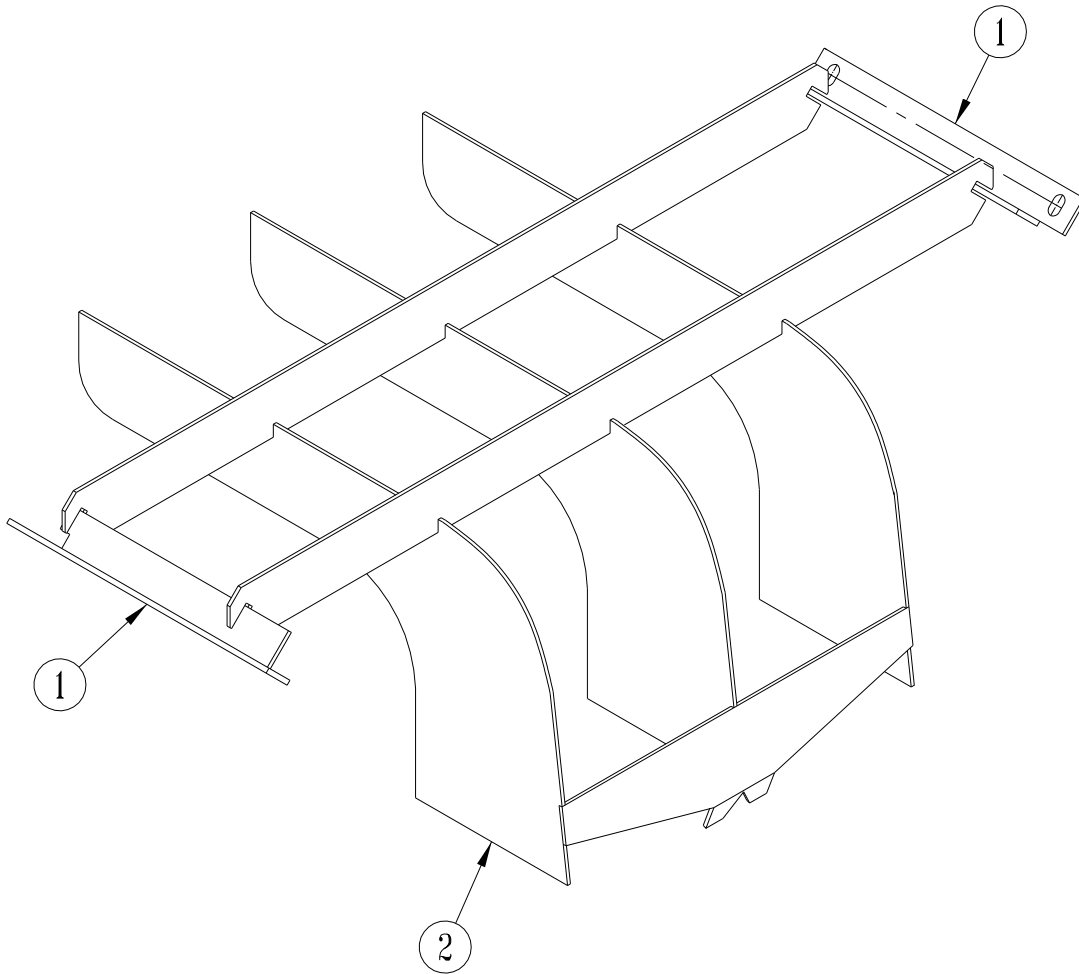

**OPTIONAL HILLSIDE FLOW DIVIDER**

<u>ITEM</u>	<u>PART NO.</u>	<u>DESCRIPTION</u>	<u>QTY.</u>
	1236-451	Assembly - Hillside Flow Divider	
1	1234-452	Bracket - Mounting Requires: 1200-302SS (2) Carriage Bolt - 3/8" UNC x 1" S/S 1209-41 (2) Flat Washer - 3/8" S/S 1209-43 (2) Lock Washer - 3/8" S/S 1205-27 (2) Nut - 3/8" UNC S/S Per Bracket	1 -RH, 1 -LH
2	1236-453	Weldment - Hillside Flow Divider	1

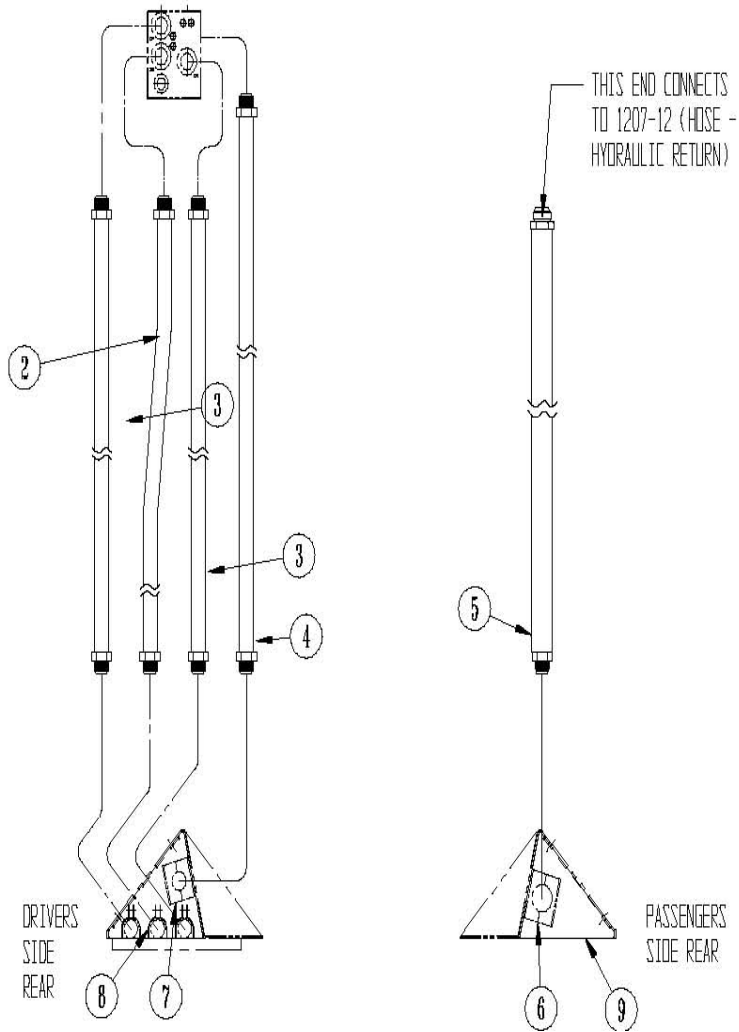

**HYDRAULIC PIPES**

**FORCE UNLTD.      SPREADER \* CONVEYORS**

ITEM	PART NO.	DESCRIPTION	QTY.
2	1234-532 1234-533 1234-534 1234-535 1236-536 1236-537 1236-538 1236-539 1236-530 1236-531 1236-532 1236-533 1236-534 1236-5346	Hydraulic Pipe -12' Box Hydraulic Pipe -13' Box Hydraulic Pipe -14' Box Hydraulic Pipe -15' Box Hydraulic Pipe -16' Box Hydraulic Pipe -17' Box Hydraulic Pipe -18' Box Hydraulic Pipe -19' Box Hydraulic Pipe -20' Box Hydraulic Pipe -21' Box Hydraulic Pipe -22' Box Hydraulic Pipe -23' Box Hydraulic Pipe -24' Box Hydraulic Pipe -26' Box	1
3	1234-522 1234-523 1234-524 1234-525 1236-526 1236-527 1236-528 1236-529 1236-520 1236-521 1236-522 1236-523 1236-524 1236-5246	Hydraulic Pipe -12' Box Hydraulic Pipe -13' Box Hydraulic Pipe -14' Box Hydraulic Pipe -15' Box Hydraulic Pipe -16' Box Hydraulic Pipe -17' Box Hydraulic Pipe -18' Box Hydraulic Pipe -19' Box Hydraulic Pipe -20' Box Hydraulic Pipe -21' Box Hydraulic Pipe -22' Box Hydraulic Pipe -23' Box Hydraulic Pipe -24' Box Hydraulic Pipe -26' Box	2
4	1234-552 1234-553 1234-554 1234-555 1236-556 1236-557 1236-558 1236-559 1236-550 1236-551 1236-552 1236-553 1236-554 1236-5546	Hydraulic Pipe -12' Box Hydraulic Pipe -13' Box Hydraulic Pipe -14' Box Hydraulic Pipe -15' Box Hydraulic Pipe -16' Box Hydraulic Pipe -17' Box Hydraulic Pipe -18' Box Hydraulic Pipe -19' Box Hydraulic Pipe -20' Box Hydraulic Pipe -21' Box Hydraulic Pipe -22' Box Hydraulic Pipe -23' Box Hydraulic Pipe -24' Box Hydraulic Pipe -26' Box	1
5	1234-542 1234-543 1234-544 1234-545 1236-546 1236-547 1236-548 1236-549 1236-540 1236-541 1236-542 1236-543 1236-544 1236-5446	Hydraulic Pipe -12' Box Hydraulic Pipe -13' Box Hydraulic Pipe -14' Box Hydraulic Pipe -15' Box Hydraulic Pipe -16' Box Hydraulic Pipe -17' Box Hydraulic Pipe -18' Box Hydraulic Pipe -19' Box Hydraulic Pipe -20' Box Hydraulic Pipe -21' Box Hydraulic Pipe -22' Box Hydraulic Pipe -23' Box Hydraulic Pipe -24' Box Hydraulic Pipe -26' Box	1
6	1208-93	Clamp - Pipe	2 (12'-14' Boxes) 3 (16'-26' Boxes)
7	1208-92	Clamp Pipe	1 (12'-14' Boxes) 2 (16'-26' Boxes)
8	1208-96	Clamp - Pipe	3
9	1234-559  1200-3011 1205-27 1209-43	Cap-Hydraulic Line Cover Requires: (2) Hexhead Capscrew - 3/8"UNC 1"SS (2) Hex Nut - 3/8" UNC SS (2) Lock Washer - 3/8" SS Per Cover	1-RH, 1-LH



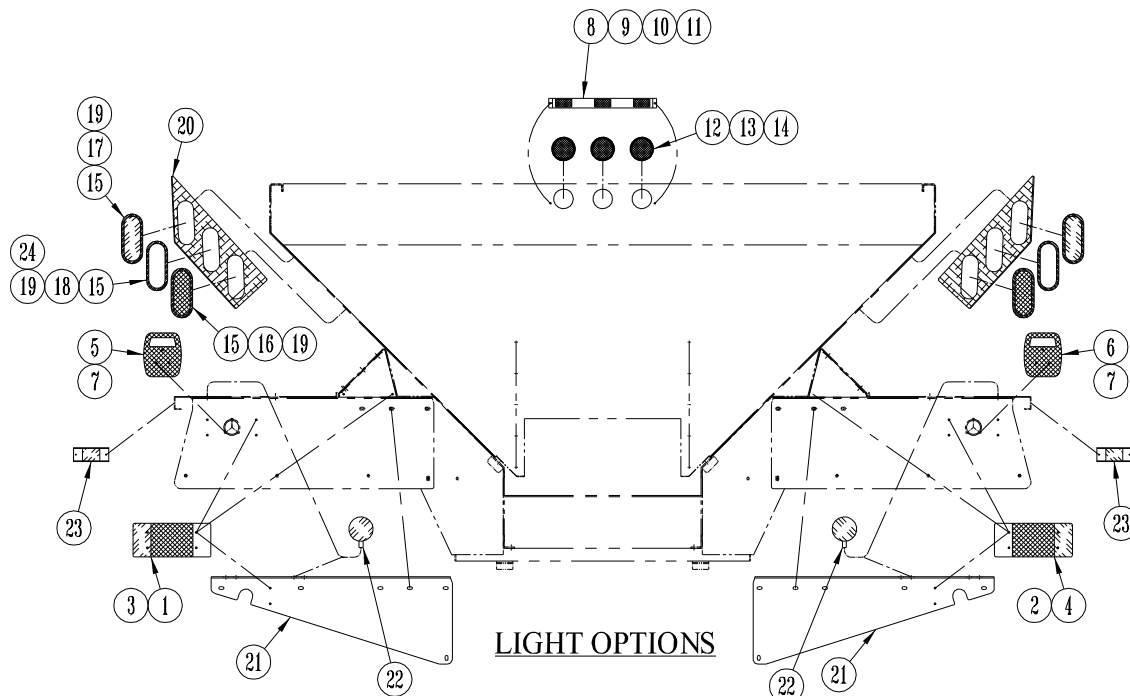

ITEM	PART NO.	DESCRIPTION	QTY.
1	1214-270L	Assembly - Left Hand - Tail Light, Red/Amber/Clear	1
2	1214-270R	Assembly - Right Hand - Tail Light, Red/Amber/Clear	1
	1223-752	Wiring Harness for 1214-270	1
	1223-753	Extension Cable - from 1223-752 to tractor 7 terminal connector (req'd on trailer units only)	1
3	1214-271L	Lens - Left Hand, Red/Amber/Clear	As Req'd
4	1214-271R	Lens - Right Hand, Red/Amber/Clear	As Req'd
5	1214-250L	Assembly - Left Hand - Tail Light, Red/Clear	1
6	1214-250R	Assembly - Right Hand - Tail Light, Red/Clear	1
7	1214-2	Assembly - Universal - Tail Light, Red/Clear	2
8	1214-290	Assembly - ID Bar, SS, 3-Light	1
9	1214-291	Housing - ID Bar - SS	As Req'd
10	1214-292	Lamp - 12V - Red	As Req'd
11	1214-293	Wiring Harness - ID Bar	As Req'd
12	1214-282	Marker Light - Red	3
13	1214-282G	Grommet - Round	3
14	1214-282P	Pigtail	3
15	1214-283G	Grommet - Oval	6
16	1214-283R	Oval Lamp - Red	2
17	1214-283Y	Oval Lamp - Yellow	2
18	1214-283C	Oval Lamp - Clear	2
19	1214-283P	Pigtail	6
20	1236-250	Weldment - Tail Light Box Requires: 1200-302SS (2) Carriage Bolt - 3/8" UNC X 1" SS 1205-27 (2) Nut - 3/8" SS 1209-43 (2) Lock Washer - 3/8" SS 1209-41 (2) Flat Washer - 3/8" SS Per Weldment	1-RH, 1-LH
21	1234-603	Wide Tail Light Bracket - Optional on Agforce LTD & Trailers Requires: 1209-43 (2) Lock Washer - 3/8" SS 1205-27 (2) Nut - 3/8" UNC SS 1200-302SS (2) Carriage Bolt - 3/8" UNC x 1" SS Per Bracket	1-RH, 1-LH
22	1214-25	Flasher - Amber	2
23	1214-284Y	Side Marker - Yellow	2
	1214-284R	Side Marker - Red	2
24	1214-283S	Oval Lamp - Yellow Strobe	As Req'd

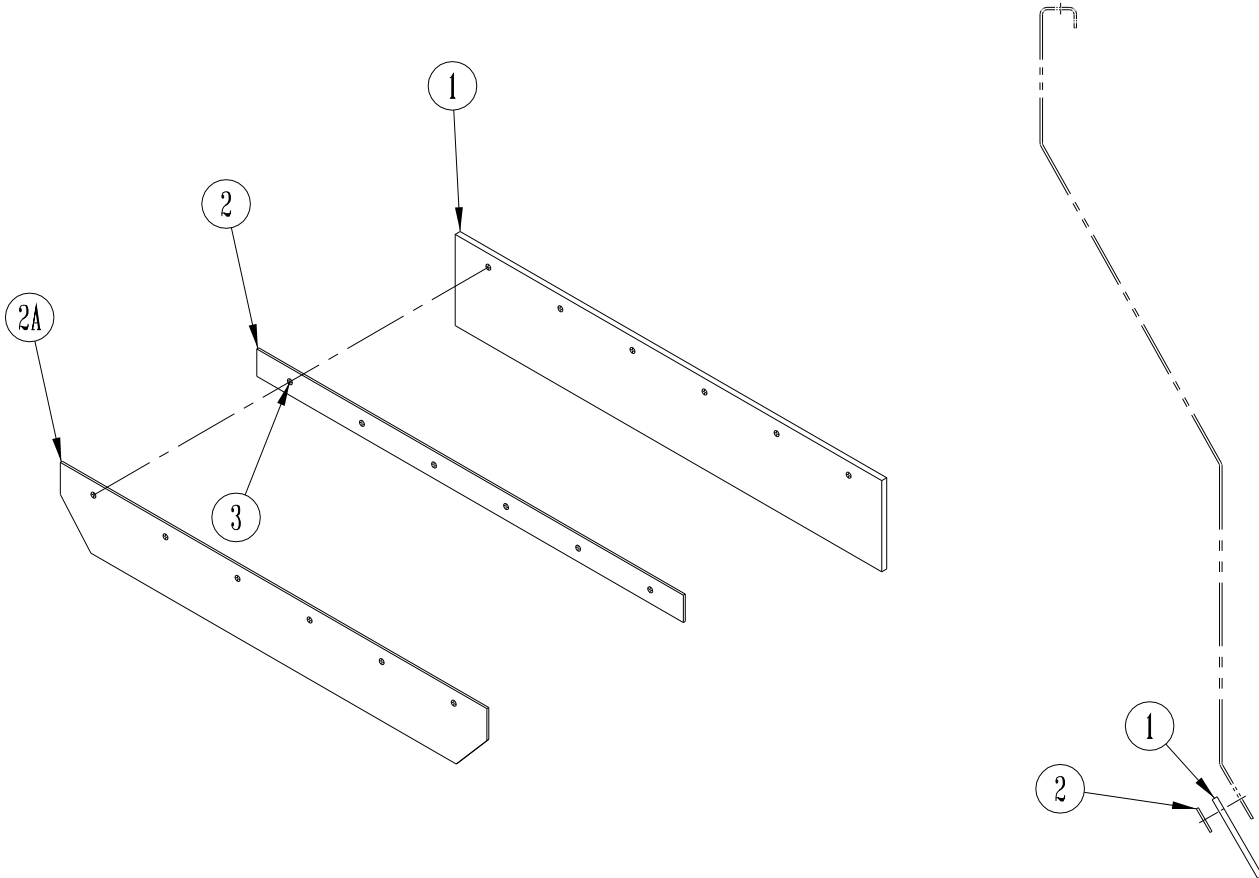

**FRONT BELT SEALER**

<u>ITEM</u>	<u>PART NO.</u>	<u>DESCRIPTION</u>	<u>QTY</u>
1	1236-905 1236-905HT 1236-905SC	Front Belt Sealer Strip Front Belt Sealer Strip - High Temp Front Belt Sealer Strip - Straight Chain	1
2 2A	1236-906 1236-906SC	Back Plate For Units w/Belt Over Chain Back Plate For Units w/Straight Chain Only	1 1
3	1200-202 1209-22 1205-11	(6) Hex Head Cap Screw - 1/4" UNC x 1" S/S (6) Lock Washer - 1/4" S/S (6) Nut - 1/4" UNC S/S	

## BOX WINDOW - OPTIONAL

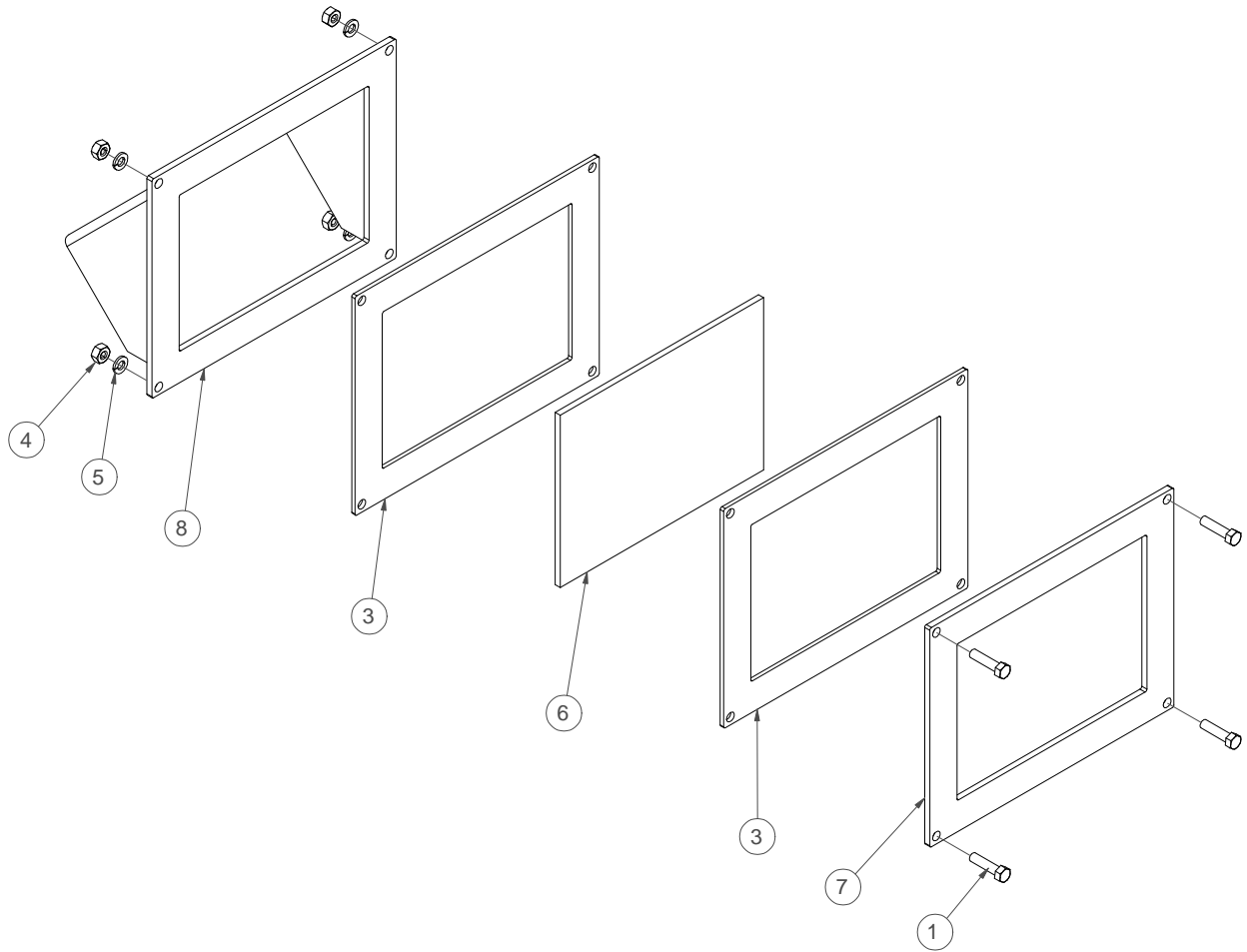

1234-950 Window Assembly - Complete (Includes items 1 - 8)

ITEM	PART NO.	DESCRIPTION	QTY
1	1200-2049	Hex Head Capscrew - 1/4" UNC x 1 1/2" L	4
3	F 1026	Gasket - Cork	2
4	1205-11	Nut - 1/4" UNC SS	4
5	1209-22	Lock Washer - 1/4" SS	4
6	F 1025	Window	1
7	1234-952	Back Plate - Window	1
8	1234-951	Weldment - Window Guard	1



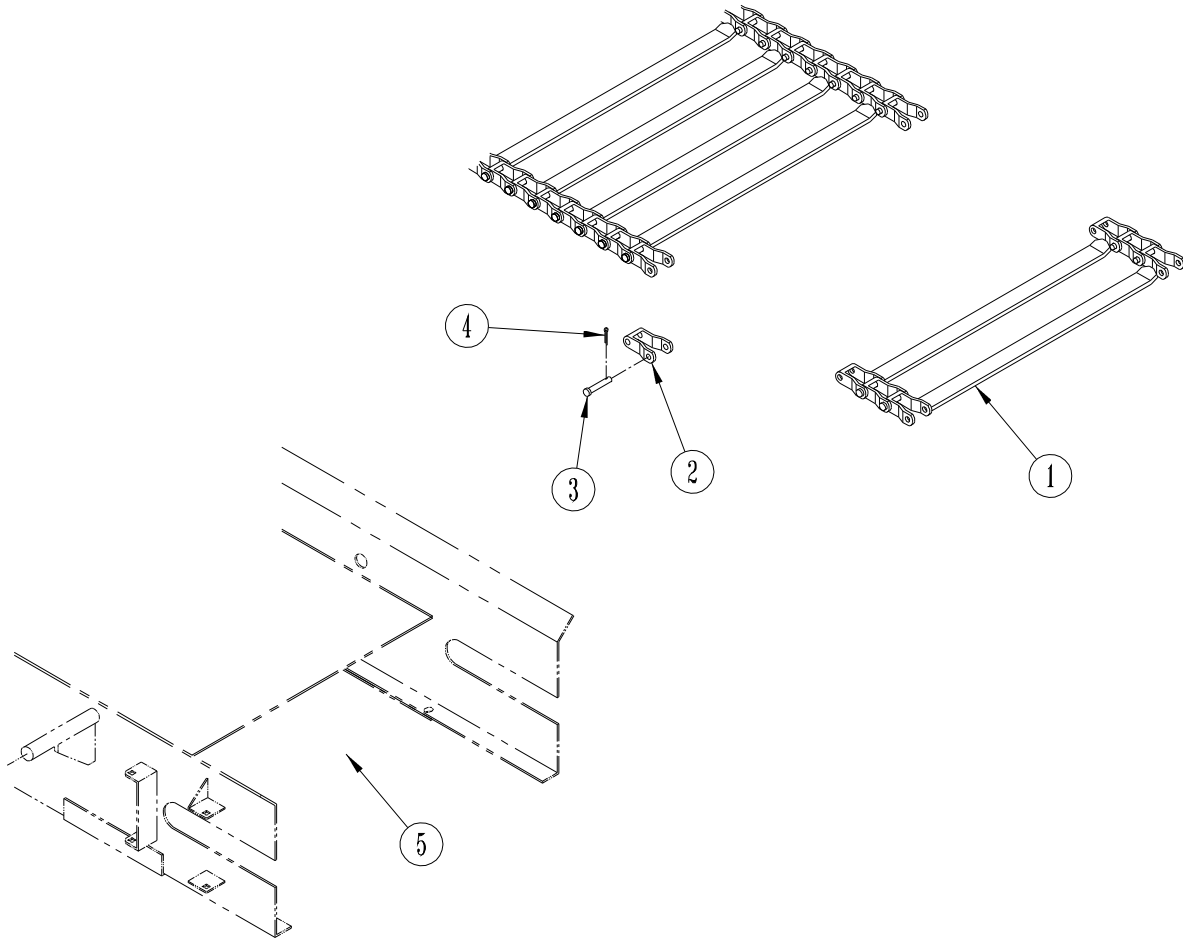

**STRAIGHT CHAIN**

ITEM	PART NO.	DESCRIPTION	QTY.
1	1236-907	Weldment - Crossbar	As Req'd
2	1234-901	Link - Pintle Chain	As Req'd
3	1234-902	Pin - Pintle Chain	As Req'd
4	1234-903	Cotter Pin	As Req'd
	1236-9XX	Assembly - #2 Straight Chain - Bar every other link (Specify Box Length)	As Req'd
	1236-9XX	Assembly - #3 Straight Chain - Bar every link (Specify Box Length)	As Req'd
5	1236-904AR	Conveyor Bed Extension Abbrasive resistant mat'l (Req'd on all Straight Chain Units Only)	1
5	1236-904SS	Conveyor Bed Extension Stainless Steel mat'l (Req'd on all Straight Chain Units Only)	1

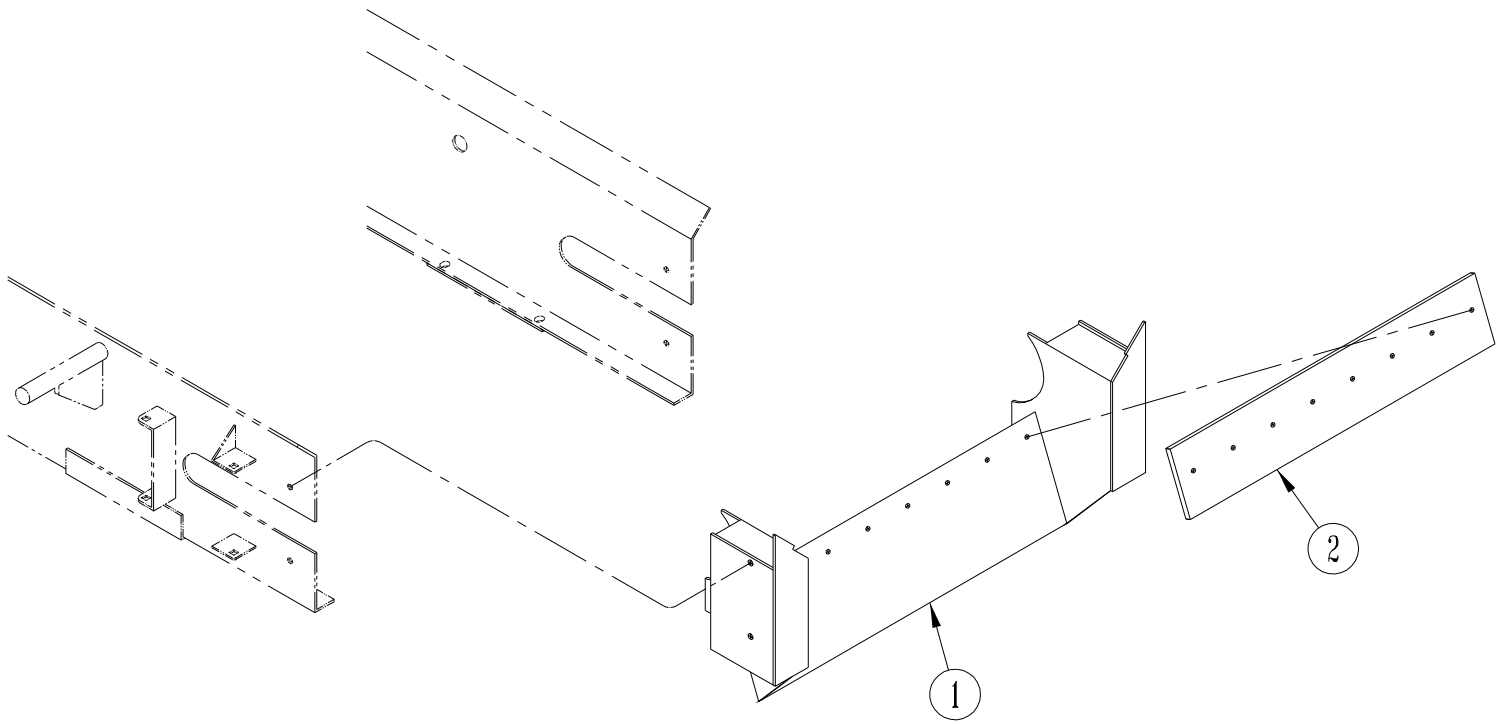

**OPTIONAL SLIDE / SCRAPER**

<u>ITEM</u>	<u>PART NO.</u>	<u>DESCRIPTION</u>	<u>QTY</u>
1	1236-328 1236-329	Weldment - Slide (BOC Units) Weldment - Slide (Straight Chain Units)	1
	1209-40 1209-42 1200-301	Requires: (4) Flat Washer - 3/8" (4) Lock Washer - 3/8" (4) Hex Head Cap Screw - 3/8" UNC x 1"	
2	1000-29TK	Scraper	1
	1200-248 1209-40C 1205-17	Requires: (8) Flat Head Socket Cap Screw - 5/16" UNC x 3/4" (8) Washer - 3/8" Dimpled (8) Lock Nut - 5/16" UNC	

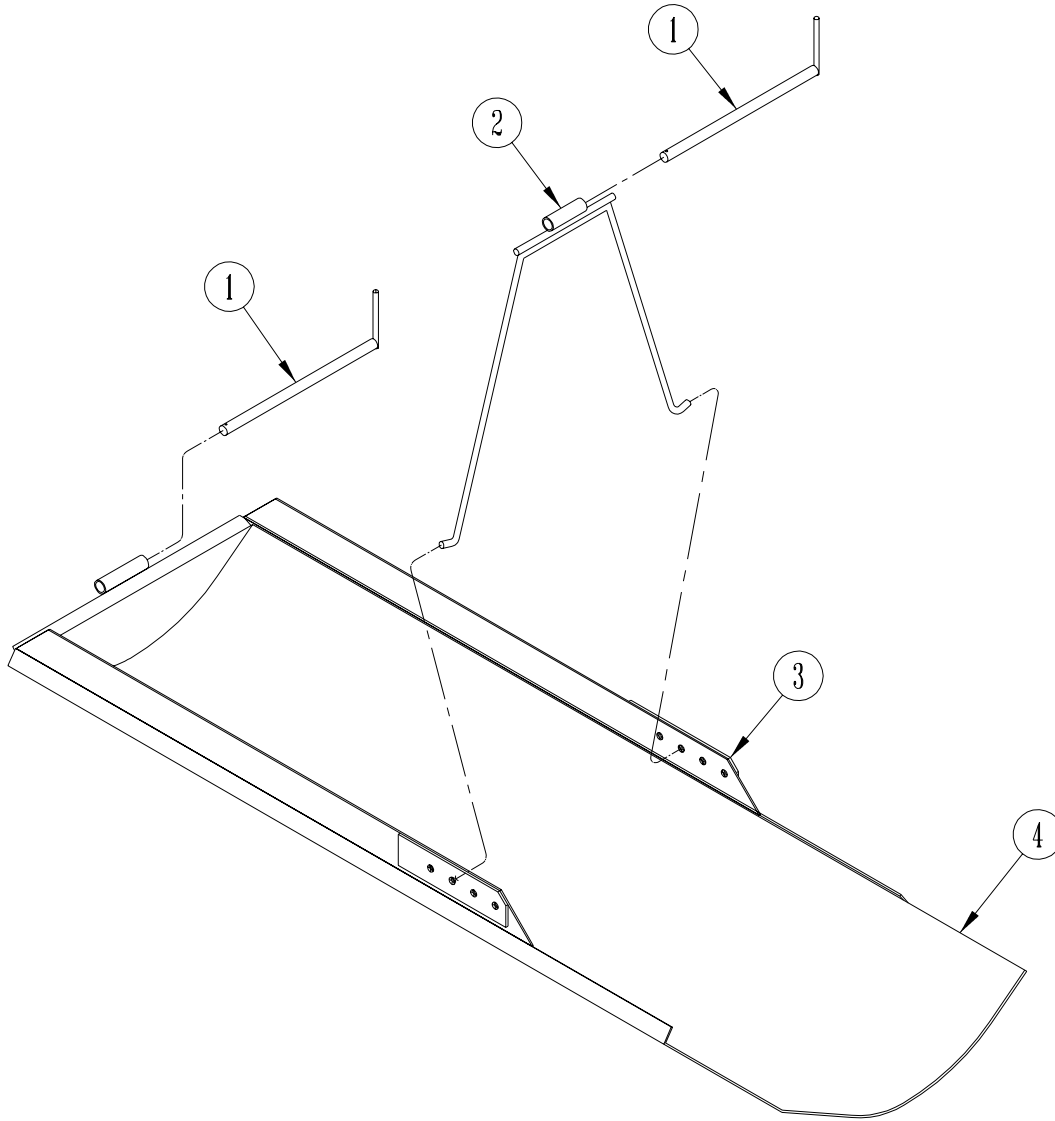

**OPTIONAL ASPHALT CHUTE**

ITEM	PART NO.	DESCRIPTION	QTY
1	1208-035	Pin	2
	1208-03	Requires: (1) 5/32" x 2-1 5/16" Hair Pin Cotter Pin Per Pin	
2	1236-325	Bracket - Pivot	1
3	1236-326	Weldment - Asphalt Chute	1
4	1236-327	Liner - UHMW	1
	1200-203	Requires: (1) Hex Head Cap Screw - 1/4" UNC x 1"	
	1209-20	(1) Flat Washer - 1/4"	
	1205-10	(1) Lock Nut - 1/4" UNC	

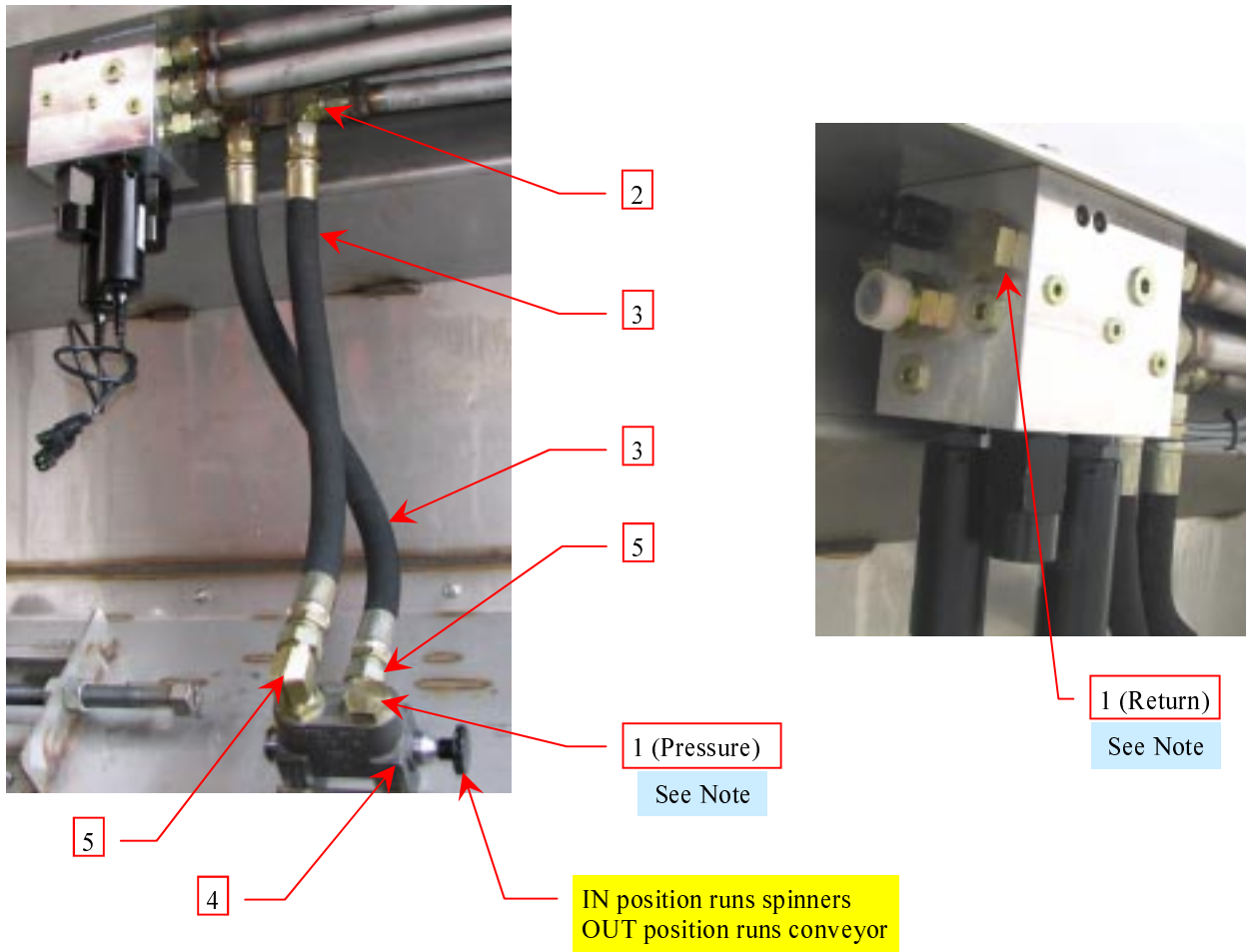

NOTE: Spinner circuit controls conveyor.

## Optional Remote Conveyor Hydraulics

<u>ITEM</u>	<u>PART NO.</u>	<u>DESCRIPTION</u>	<u>QTY.</u>
	1202-500	Assembly (Includes items 1 thru 5)	1
1	1202-120	Plug (Note: Remove plugs & install quick couplers with adequate pressure/return hose where applicable)	2
2	1202-199	Weldment - Adapter	1
3	1207-500	Hose Ass'y	2
4	1222-20	Valve - Selector Requires: 1200-307 1205-21 1209-42	1
5	1202-201	Adapter - Elbow	2

# FORCE UNLTD.

SPREADERS \* GPS EQUIPMENT \* CONVEYORS

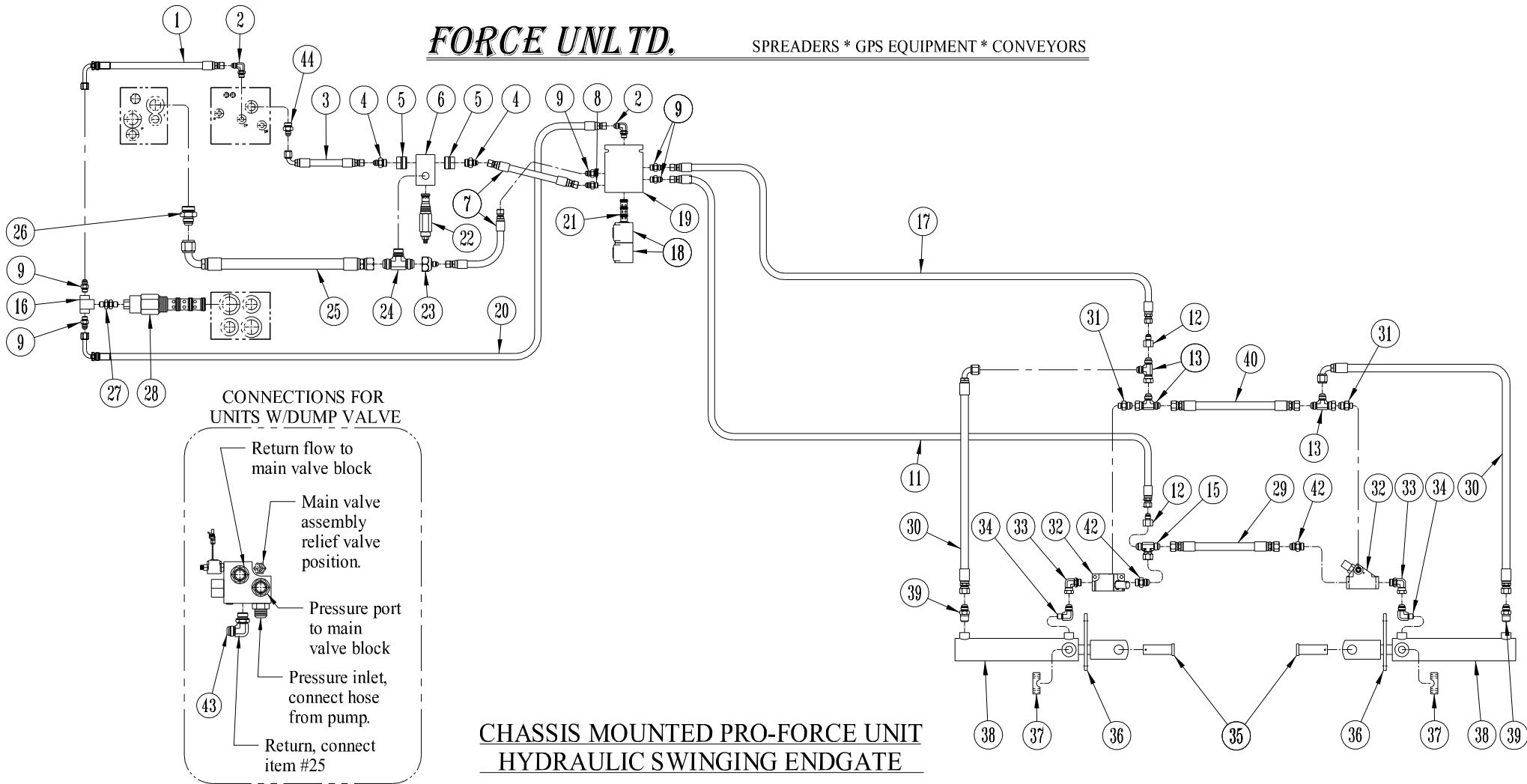

**CONNECTIONS FOR UNITS W/DUMP VALVE**

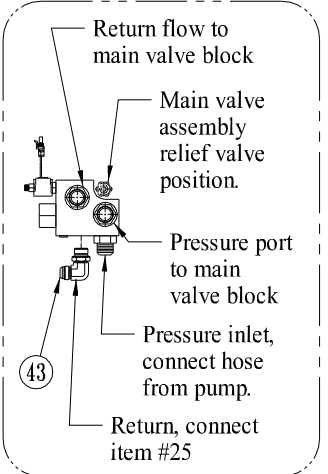

**CHASSIS MOUNTED PRO-FORCE UNIT  
HYDRAULIC SWINGING ENDGATE**

ITEM	PART NO.	DESCRIPTION	QTY.
1	1207-801	Hose Assy	1
2	1202-2056	Adapter - Elbow	2
3	1207-802	Hose Assy	1
4	1202-1075	Adapter - Straight	2
5	1202-130	Adapter - Straight	2
6	1211-940	Valve Body Requires: (2) Hex Head Capscrew - 1/4" UNC x 3/4" Lg. (2) Lock Washer - 1/4"	1
	1200-200		
	1209-21		
7	1207-805	Hose Assy	2
8	1202-10745	Adapter - Straight	1
9	1202-1074	Adapter - Straight	5
10			
11	1207-8095	Hose Assy	1
12	1202-1029	Adapter - Straight	2
13	1202-3014	Adapter - Tee	3
14			
15	1202-285	Adapter - Tee	1
16	1222-7	Valve - Shuttle	1
17	1207-808	Hose Assy	1
18	1222-110CA	Coil	2
19	1211-58C	Valve Body Requires: (2) Hex Head Capscrew - 1/4" UNC x 2 1/4" Lg. SS (2) Lock Washer - 1/4" SS (2) Flat Washer - 1/4" SS	1
	1200-208		
	1209-22		
	1209-25S		
20	1207-803	Hose Assy	1
21	1211-58C1	Valve	1
22	1211-94	Valve - Hydraulic Relief	1
23	1202-1030	Adapter - Straight	1
24	1202-60	Adapter - Tee	1
25	1207-804	Hose Assy - Units w/Dump Valve Block	1
	1207-8045	Hose Assy - Units w/o Dump Valve Block	1
26	1202-113	Adapter - Straight	1
27	1202-25	Adapter - Straight	1
28	1211-801	Modified PSI Compensator Cartridge	1
29	1207-703	Hose Assembly	1
30	1207-701	Hose Assembly	2
31	1202-10750	Adapter - Straight	2
32	1211-98	Valve Body	2
33	1202-2094	Adapter - Elbow	2
34	1202-1041	Adapter - Elbow	2
35	1236-651SS	Pin - Hyd. Cylinder Requires: (1) Hex Head Capscrew - 1/4 UNC x 1-1/2 SS (1) Lock Nut - 1/4 UNC SS Per Pin	2
	1200-2049		
	1205-501		
36	1100-150S	Seal Strip - Cylinder Rod Requires: (3) Hex Head Capscrew - 1/4" UNC x 1" SS (3) Flat Washer - 1/4" SS (3) Lock Washer - 1/4" SS (3) Nut - 1/4" UNC SS Per Seal Strip	2
	1200-202		
	1209-25S		
	1209-22		
	1205-11		
37	1100-150C	Clamp - Trunnion Requires: (2) Hex Head Capscrew - 3/8 UNC x 1-1/4 SS (2) Lock Washer - 3/8" SS	4
	1200-303SS		
	1209-43		
38	1100-150	Hyd. Cylinder	2
39	1202-1001	Adapter - Straight	2
40	1207-702	Hose Assembly	1
41			
42	1202-1076	Adapter - Straight	2
43	1202-202	Adapter - Elbow	1
44	1202-1073	Adapter - Straight	1

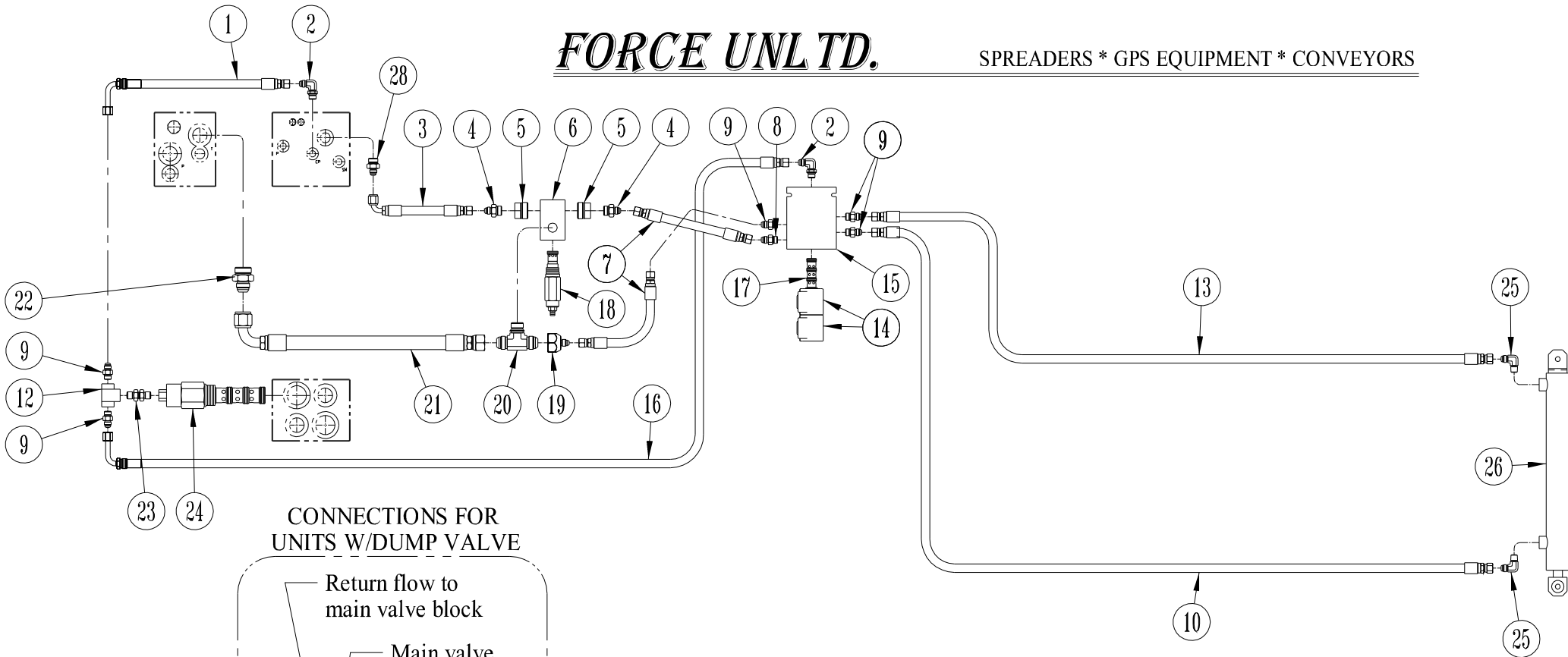

**CONNECTIONS FOR  
UNITS W/DUMP VALVE**

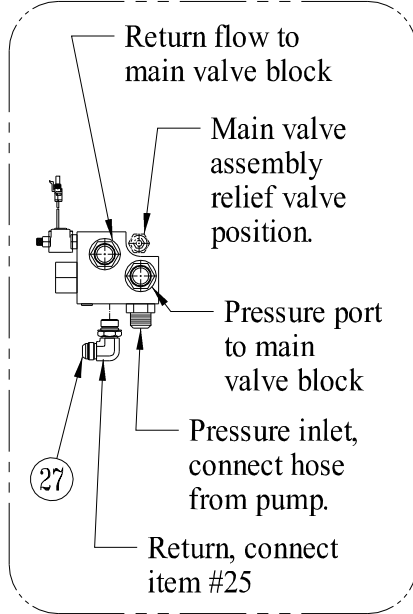

**HYDRAULIC FEEDGATE**

ITEM	PART NO.	DESCRIPTION	QTY.
1	1207-801	Hose Assy	1
2	1202-2056	Adapter - Elbow	2
3	1207-802	Hose Assy	1
4	1202-1075	Adapter - Straight	2
5	1202-130	Adapter - Straight	2
6	1211-940	Valve Body Requires: 1200-200 (2) Hex Head Capscrew - 1/4" UNC x 3/4" Lg. 1209-21 (2) Lock Washer - 1/4"	1
7	1207-805	Hose Assy	2
8	1202-10745	Adapter - Straight	1
9	1202-1074	Adapter - Straight	5
10	1207-809	Hose Assy	1
12	1222-7	Valve - Shuttle	1
13	1207-808	Hose Assy	1
14	1222-110CA	Coil	2
15	1211-58C	Valve Body Requires: 1200-208 (2) Hex Head Capscrew - 1/4" UNC x 2 1/4" Lg. SS 1209-22 (2) Lock Washer - 1/4" SS 1209-25S (2) Flat Washer - 1/4" SS	1
16	1207-803	Hose Assy	1
17	1211-58C1	Valve	1
18	1211-94	Valve - Hydraulic Relief	1
19	1202-1030	Adapter - Straight	1
20	1202-60	Adapter - Tee	1
21	1207-804	Hose Assy - Units w/Dump Valve Block	1
	1207-8045	Hose Assy - Units w/o Dump Valve Block	1
22	1202-113	Adapter - Straight	1
23	1202-25	Adapter - Straight	1
24	1211-801	Modified PSI Compensator Cartridge	1
25	1202-1045	Adapter - Elbow	2
26	1222-17	Hydraulic Cylinder Requires: Lower Tab Requires: (1) Hex Head Capscrew - 3/8" UNC x 3" Lg. (1) Lock Washer - 3/8" (1) Nut - 3/8" UNC Upper Tab Requires: (1) Hex Head Capscrew - 3/8" UNC x 2-1/2" Lg. (1) Lock Washer - 3/8" (1) Nut - 3/8" UNC	1
27	1202-202	Adapter - Elbow	1
28	1202-1073	Adapter - Straight	1



# ***FORCE UNLTD.***

SPREADERS \* GPS EQUIPMENT \* CONVEYORS

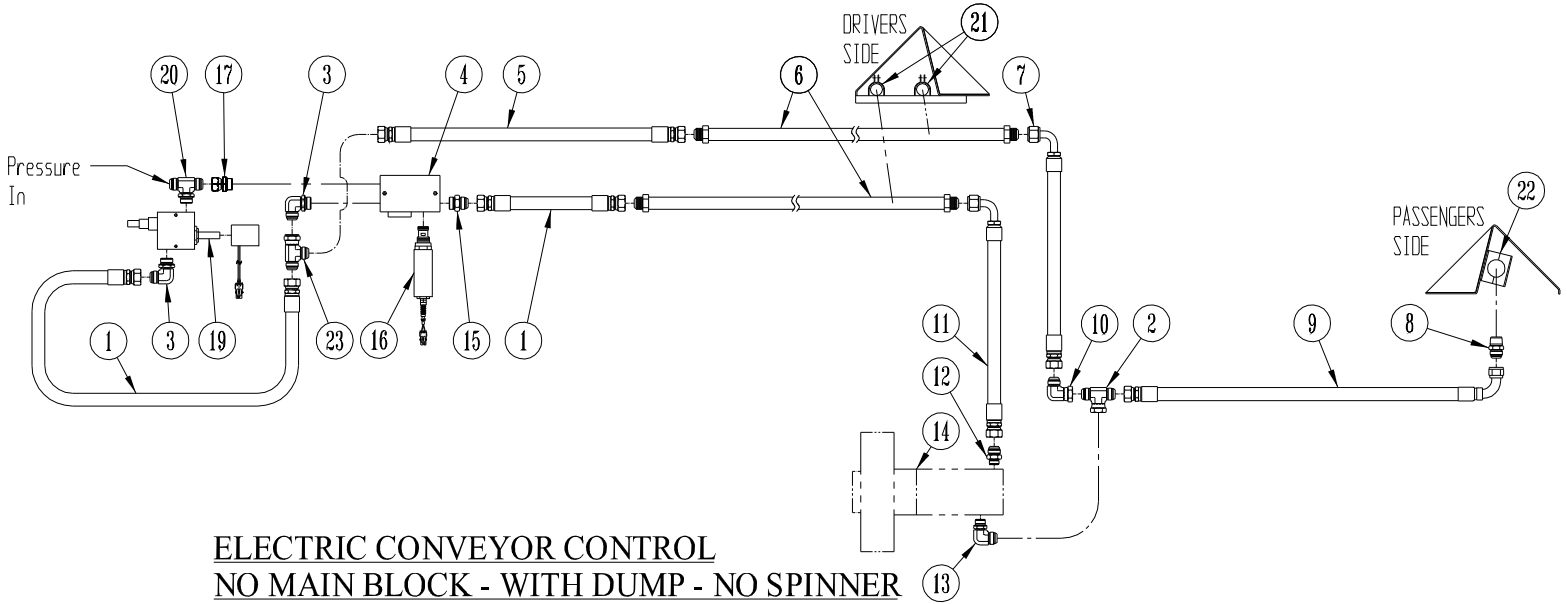

## **ELECTRIC CONVEYOR CONTROL** **NO MAIN BLOCK - WITH DUMP - NO SPINNER**

ITEM	PART NO.	DESCRIPTION	QTY.
1	1207-950	Hose Assy	2
2	1202-300	Adapter - Tee	1
3	1202-201	Adapter - Elbow	2
4	1211-07	Valve Block Requires: 1200-259 (1) Hex Head Capscrew - 5/16" UNC x 3" Lg. 1205-13 (1) Lock Washer - 5/16" 1209-31 (1) Nut - 5/16" UNC	1
5	1207-951	Hose Assy	1
6	1236-600	Hydraulic Pipe	2
7	1207-03	Hose Assy	1
8	1202-102	Adapter - Straight	1
9	1207-06	Hose Assy	1
10	1202-200	Adapter - Elbow	1
11	1207-041	Hose Assy	1
12	1202-111	Adapter - Straight	1
13	1202-204	Adapter - Elbow	1
14		Gearbox See Pg. 1	1
15	1202-116	Adapter - Straight	1
16	1211-03A	Valve - Hydraulic Servo	1
17	1202-117	Adapter - Straight	1
18			
19	1211-173	Dump Valve - Cartridge Requires: 1200-259 (1) Hex Head Capscrew - 5/16" UNC x 3" Lg. 1205-13 (1) Lock Washer - 5/16" 1209-31 (1) Nut - 5/16" UNC	1
20	1202-62	Adapter - Tee	1
21	1208-96	Clamp - Pipe	4
22	1208-93	Clamp - Pipe	2
23	1202-3015	Adapter - Tee	1

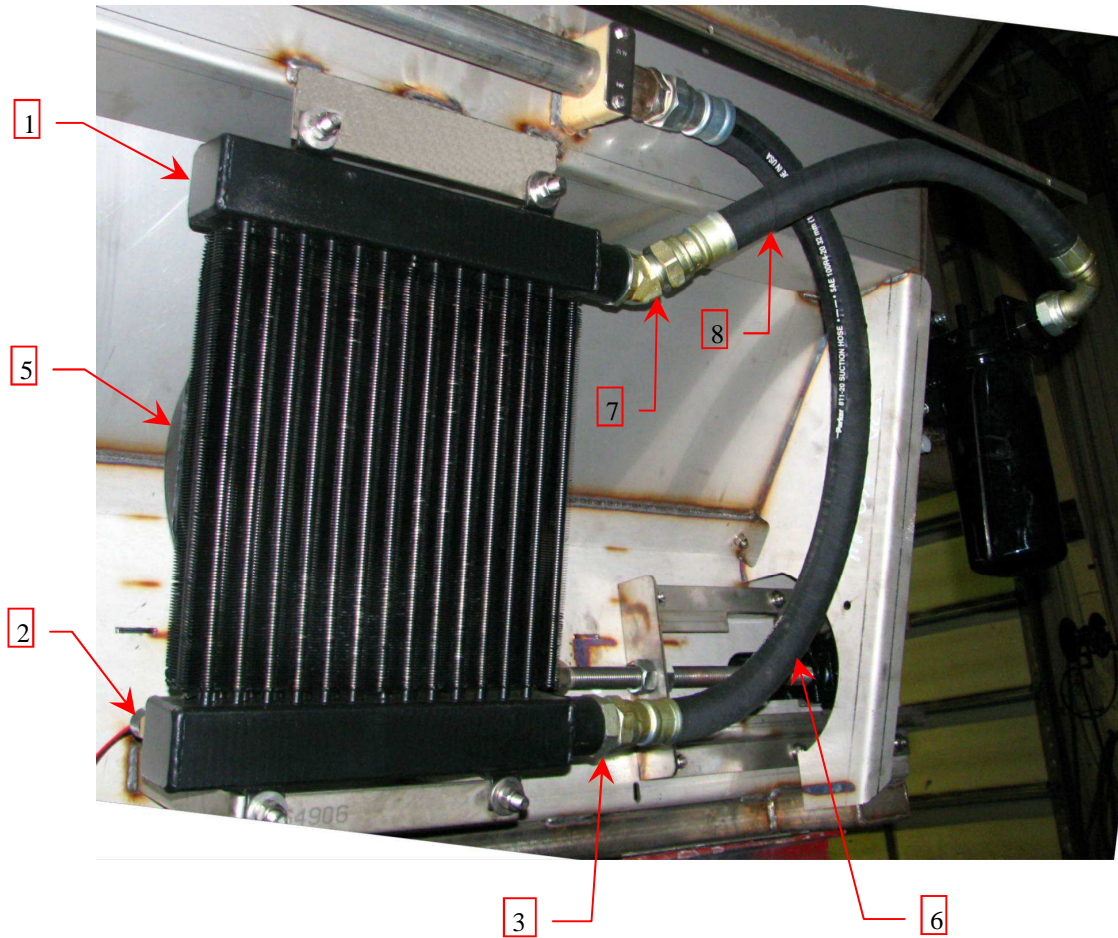

## Optional Oil Cooler

<u>ITEM</u>	<u>PART NO.</u>	<u>DESCRIPTION</u>	<u>QTY.</u>
1	1222-544 1200-350 1209-61 1209-63 1205-36	Oil Cooler Requires: (4) Hex Head Capscrew - 1/2" UNC x 1-1/2" SS (4) Flat Washer - 1/2" SS (4) Lock Washer - 1/2" SS (4) Nut - 1/2" UNC SS	1
2	1214-340	Temperature Switch	1
3	1202-11600 1202-20905	Adapter - Straight Adapter - 45 Deg. (AgChem 8303 Chassis)	1 1
4			
5	1223-544 1223-544 AG	Wire Harness Wire Harness for use on AgChem 8303 Chassis	1
6	1207-415C	Hose	1
7	1202-20905	Adapter - 45 Deg.	1
8	1207-027	Hose	1

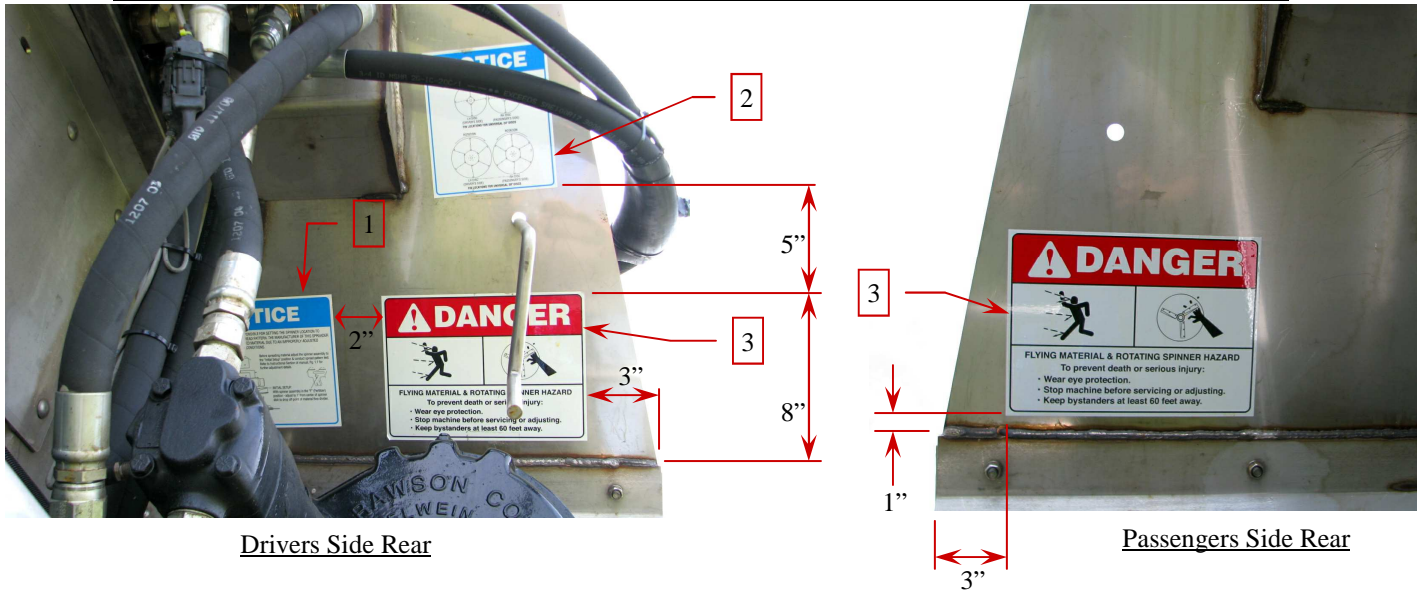

Drivers Side Rear

Passengers Side Rear

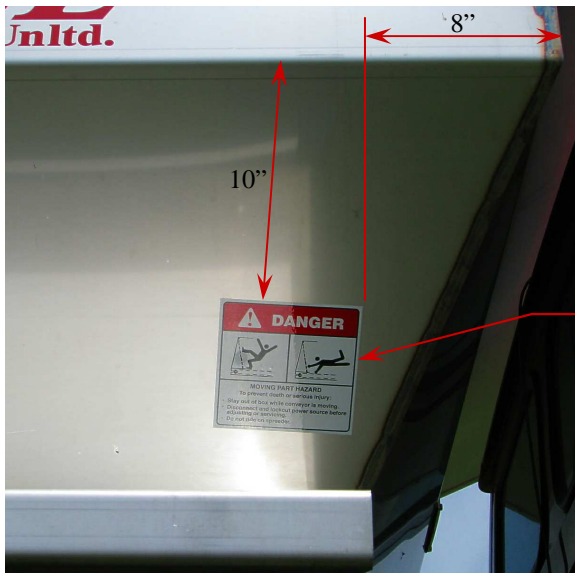

Passengers Side Front



Drivers Side Front

## Safety Decals

<u>ITEM</u>	<u>PART NO.</u>	<u>DESCRIPTION</u>	<u>QTY.</u>
1	1234-050	Decal - Spinner Disc Location	1
2	1234-051	Decal - Fin Location on Universal Disc	1
3	1234-052	Decal - Flying Material	2
4	1234-053	Decal - To Avoid Injury or Machine Damage	1
5	1234-054	Decal - Moving Part Hazard	2

## OPTIONAL 12" H SS BOX EXTENSIONS FOR 102" W BOX

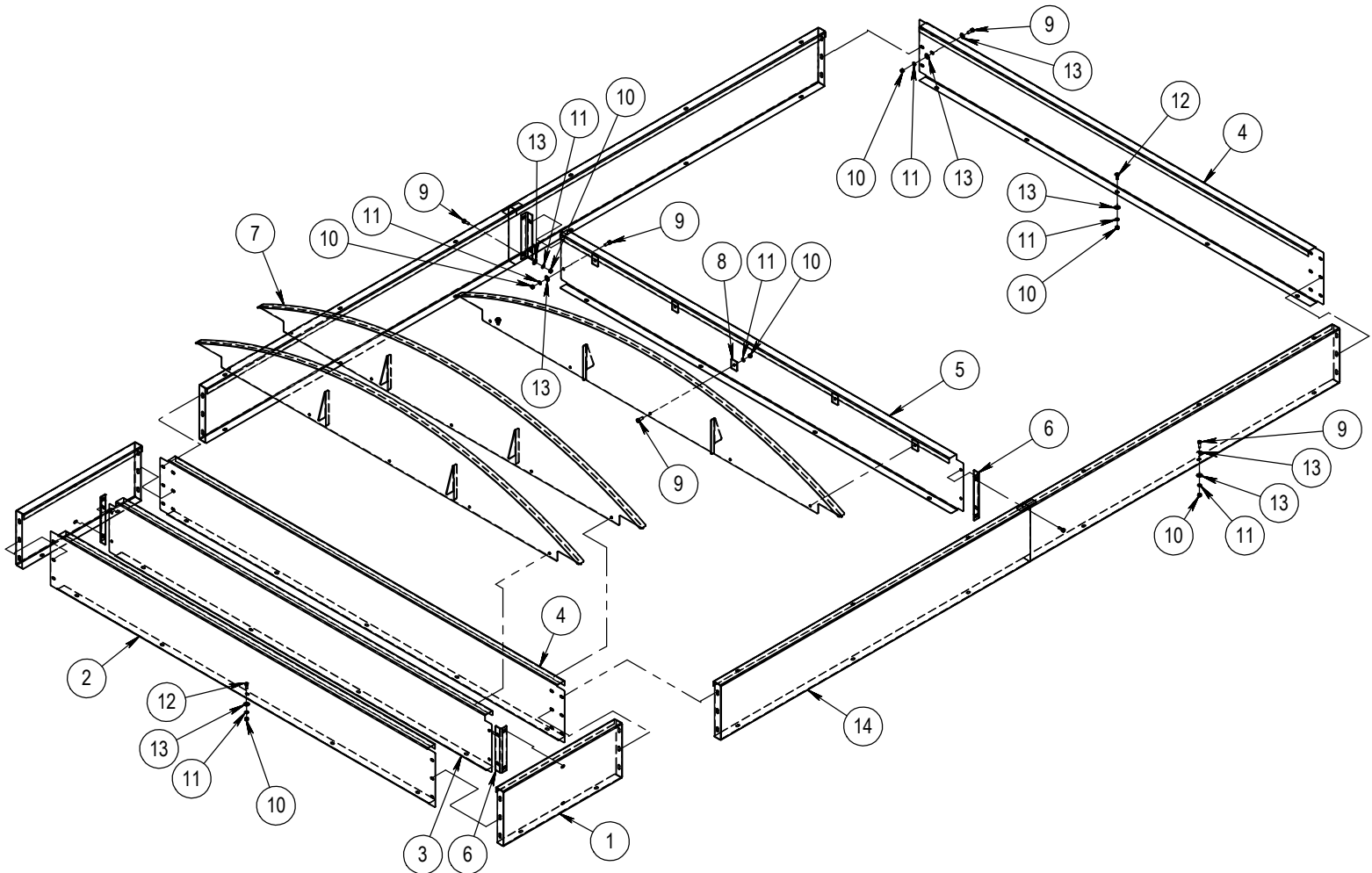

ITEM NO.	PartNo	DESCRIPTION	QTY.
1	1239-15205	12" TRI-FORCE BIN EXTENSION SIDE PANEL WELDMENT	2
2	1239-15305	12" HIGH TRI-FORCE REAR EXTENSION	1
3	1239-15405	12" HIGH TRI-FORCE BIN CENTER EXTENSION	1
4	1234-148	12" HIGH FRONT & REAR EXTENSIONS	2
5	1234-1520	12" HIGH CENTER EXTENSION	1
6	1234-1530	BRACKET FOR 12" HIGH EXTENSIONS	As Req'd
7	1237-18W	DF/TF/QF Divider Extension Weldment for use with 12" High Tarp	As Req'd
8	1234-942	BOARD EXTENSION CLIP	As Req'd
9	1200-3011	Hex Head Capscrew - 3/8" UNC x 1" SS	As Req'd
10	1205-27	Nut - 3/8" UNC SS	As Req'd
11	1209-43	Lock Washer - 3/8" SS	As Req'd
12	1200-302SS	Carriage Bolt - 3/8" UNC x 1" SS	As Req'd
13	1209-41	Flat Washer - 3/8" SS	As Req'd
14	1234-XXX	12" HIGH SIDE BOX EXTENSION (SPECIFY BOX LENGTH)	2